

**Indian National Physics Olympiad (INPhO)-2024**  
**HOMI BHABHA CENTRE FOR SCIENCE EDUCATION**  
Tata Institute of Fundamental Research  
V. N. Purav Marg, Mankhurd, Mumbai, 400 088

**Question Paper**

Date: 04 February 2024

Time: **09:00-12:00 (3 hours)**

Maximum Marks: **80**

**Instructions**

**Roll No.:**

1. This booklet consists of 9 pages and total of 6 questions. Write roll number at the top wherever asked.
2. Booklet to write the answers is provided separately. Instructions to write the answers are on the Answer Booklet.
3. Non-programmable scientific calculators are allowed. Mobile phones **cannot** be used as calculators.
4. **Please submit the Answer Sheet at the end of the examination.** You may retain the Question Paper.

**Table of Constants**

Universal constant of Gravitation	$G$	$6.67 \times 10^{-11} \text{ N}\cdot\text{m}^2\cdot\text{kg}^{-2}$
Value of $1/4\pi\epsilon_0$		$9.00 \times 10^9 \text{ N}\cdot\text{m}^2\cdot\text{C}^{-2}$
Avogadro's number	$N_A$	$6.022 \times 10^{23} \text{ mol}^{-1}$
Acceleration due to gravity	$g$	$9.81 \text{ m}\cdot\text{s}^{-2}$
Universal Gas Constant	$R$	$8.31 \text{ J}\cdot\text{K}^{-1}\cdot\text{mol}^{-1}$
	$R$	$0.0821 \text{ l}\cdot\text{atm}\cdot\text{mol}^{-1}\cdot\text{K}^{-1}$
Molar mass of Helium		$4.003 \text{ g}\cdot\text{mol}^{-1}$
Boltzmann constant	$k_B$	$1.3806 \times 10^{-23} \text{ J}\cdot\text{K}^{-1}$
Earth's radius	$R_E$	6371km
Earth's mass	$M_E$	$5.97 \times 10^{24} \text{ kg}$
Moon's mass	$M_M$	$7.35 \times 10^{22} \text{ kg}$
Moon's radius	$R_M$	1737km

Question Number	1	2	3	4	5	6	Total
Maximum Marks	8	18	14	11	18	11	80

## 1. [8 marks] An electrifying experiment

Professor Coulomb was investigating how the magnitude of the force ( $|\vec{F}|$ ) between two charged spheres depends on the distance between their centres. He conducted four separate experiments by placing two identical conducting spheres 1 and 2, each of radius  $a$ , at different distances  $d$  from each other. The experiments are outlined in the table below. Here  $Q_1$  and  $Q_2$  are the charges on the spheres 1 and 2, respectively. The measurement results are presented in the graph.

Experiment no.	$a$ (m)	$Q_1$	$Q_2$
1	0.10	$+Q$	$+Q$
2	0.10	$+Q$	$-Q$
3	0.05	$+Q$	$+Q$
4	0.05	$+Q$	$-Q$

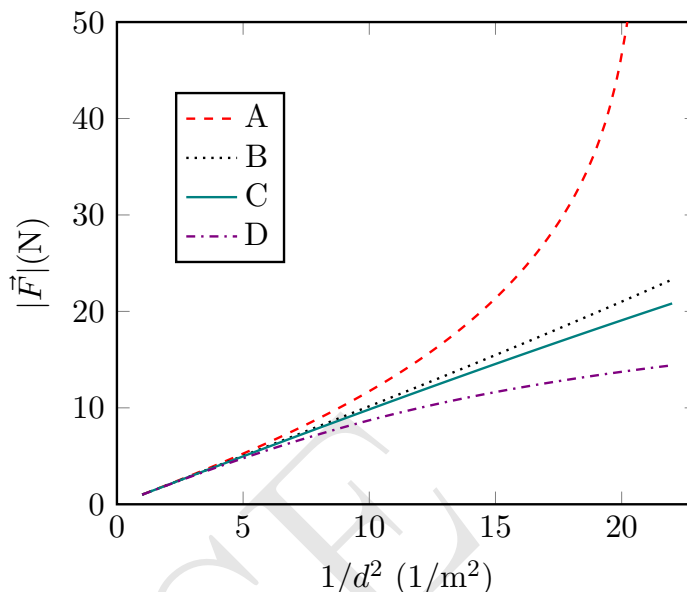
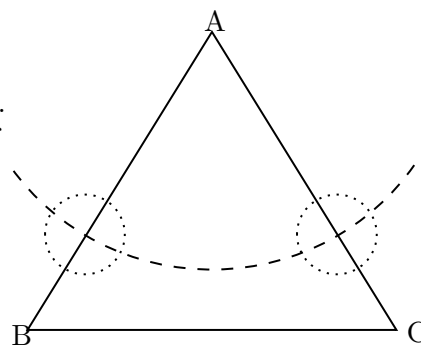

Figure out which measurement (A, B, C, D) belongs to which experiment (1, 2, 3, 4). Explain your answers in the detailed answersheet. You may draw diagrams, if necessary.

## 2. A Potpourri of Prism Problems

- (a) [7 marks] In the most common method to determine the angle of minimum deviation by a prism, we record the angles of deviation ( $\delta$ ) for various angles of incidence ( $i$ ) and then plot a graph. However, Professor Joseph proposed an ingenious idea to determine the angle of minimum deviation with just a single angle of incidence. Eager to share his breakthrough, he penned a letter to his friend, Professor Amal Nathan, outlining his method for an equilateral prism. According to Professor Joseph, the only tools required were four pins, a board, a marker pen or pencil, a scale, a protractor, and, of course, the prism. He even claimed that one may not need all the materials listed.

In his letter, Professor Joseph began to sketch a figure to illustrate the method. Here triangle ABC is the trace of the prism. The dashed curve is an arc of a circle centered at A. The dotted circles are centered on the points of intersection of the arc with the sides of the triangle. Unfortunately, he forgot to complete the figure. Can you describe the experimental method to determine the angle of minimum deviation using the unfinished figure of Professor Joseph? You must provide the following:



1. A complete ray diagram using the given figure. You may use the one already provided on the answersheet or draw a fresh one.
  2. Outline of the essential experimental steps using some or all of the equipment mentioned above and nothing more. Use the detailed answer sheet for this.
- (b) [1.5 marks] Consider a right-angled isosceles prism as depicted below. The prism is placed on a table ( $x$ - $y$  plane). The triangular faces are non-refracting surfaces. The refractive index of the prism is 1.50. The sides  $AB = AC = AD = 1$  unit. The prism is positioned such that point D is at the origin, with the axes defined in the figure. An arrow-shaped object is

pasted on the face BCFE of the prism as shown. Draw the image of the object as seen by an observer in front of the face BCFE.

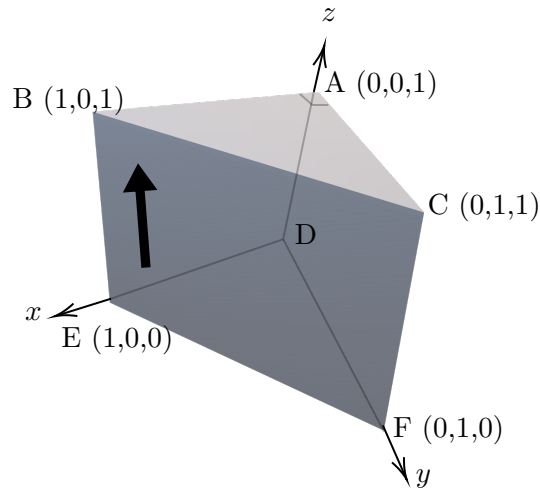

- (c) [1.5 marks] Now an object, shaped like the letter "P" as illustrated in the left figure below, is held in front of the face ABED of the prism, placed on a table ( $x$ - $y$  plane). The corresponding top view of this configuration is also presented in the right figure below.

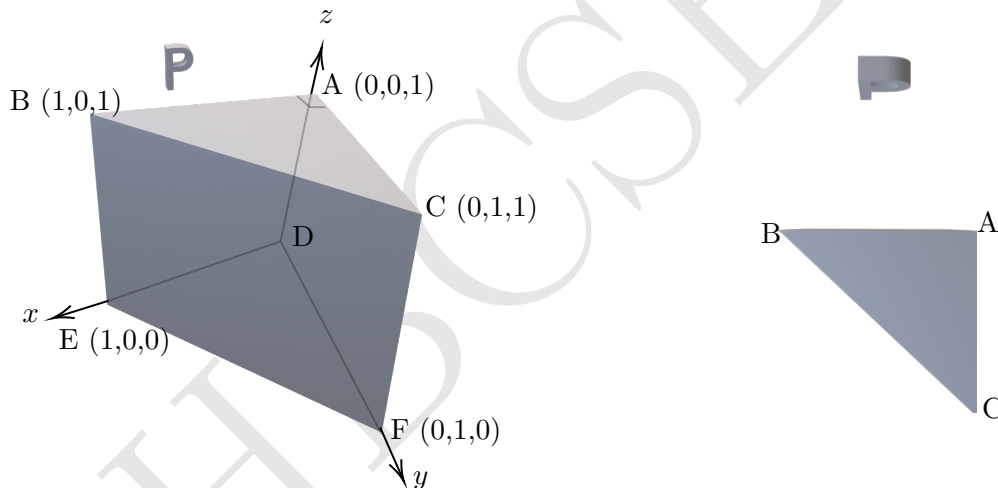

Draw the image of the "P" as seen by an observer in front the face ACFD. Additionally, draw a qualitative ray diagram illustrating the image formation.

- (d) [5 marks] In this part, alongside the setup of part (c) with the prism ABCDEF and the object "P" positioned in front of its face ABED, we introduce another identical prism,  $A'B'C'D'E'F'$  (see below).

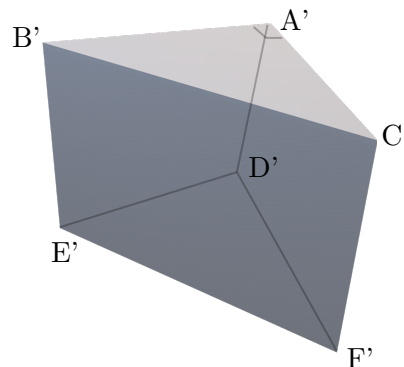

A specific experiment requires placing the prism  $A'B'C'D'E'F'$  in combination with the existing setup so that the following image (as shown below) of the object "P" can be obtained.

**b**

Without disturbing the prism ABCDEF, where and how would you hold the prism A'B'C'D'E'F' to achieve this resultant image?

Provide your answer in terms of the coordinates of the vertices of the prism A'B'C'D'E'F', taking vertex D of the first prism as the origin. Additionally, specify that to view such an image, the viewer should be facing which particular face of the prism.

*Hint:* The position of the second prism is such that any one of the parts (such as at least one of the vertices, edges, or faces) touches the table. The viewer should be positioned in a way that allows a clear line of sight to the area where the image is formed, ensuring an unobstructed view of the desired image.

- (e) [3 marks] In a spectrograph, two equilateral prisms denoted as 1 and 2 with refractive indices  $\mu_1 = 1.50$  and  $\mu_2 = 1.68$ , respectively, are placed one after another (see the figure below). The incident ray is shown on the left and the final emergent ray is shown on the right.

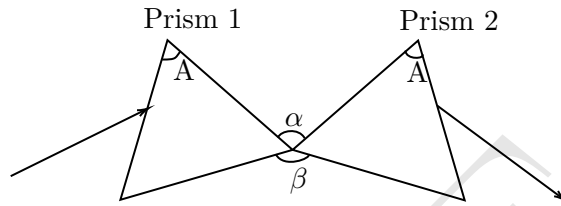

Find the angle ( $\beta$ ) between the bases of the two prisms if each prism is individually adjusted for minimum deviation for the respective incident rays. Obtain the total deviation  $\delta$  of the beam of light in this configuration. Express your answers in terms of  $\mu_1, \mu_2, A$ . Calculate  $\beta$  and  $\delta$  in degrees.

### 3. Chandrayaan-3

On July 14, 2023, India's lunar mission satellite, *Chandrayaan-3*, was successfully launched by the Indian Space Research Organization (ISRO). *Chandrayaan-3* (mass  $m = 3900$  kg) was taken to the Moon through a series of Earth Bound Manoeuvres (elliptical) orbits (EBNs) as depicted in the figure below. In this problem, we will explore the physics governing some part of its journey, employing a simplified model. For all parts of this problem except part (f), we consider *Chandrayaan-3* to be moving only under the influence of Earth's gravity (a central force).

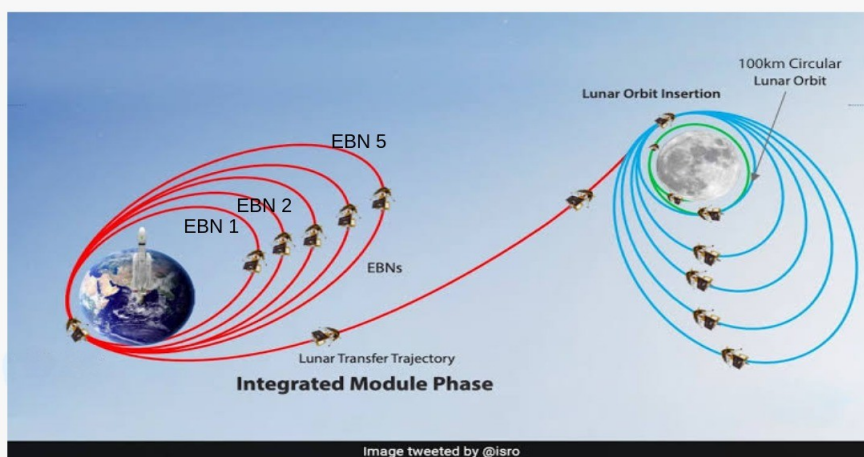

- (a) [6 marks] Upon launch, *Chandrayaan-3* entered an elliptical orbit around Earth, with Earth at one of the foci (E) as shown below. The points P and A are the perigee (nearest point from the Earth) and apogee (farthest point from the Earth), respectively. We introduce the polar coordinate system  $(r, \theta)$ , where  $\vec{r}$  is the vector from the centre of the Earth (origin) to the satellite, and  $\theta$  is the angle that  $\vec{r}$  makes with the major axis ( $PA = 2a$ ). The directions of unit vectors  $\hat{r}$  and  $\hat{\theta}$  are shown in the figure.

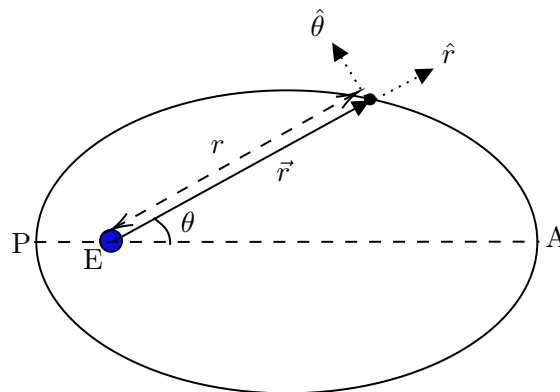

The equation of the ellipse can be written in polar coordinates as

$$r = \frac{r_0}{(1 - e \cos \theta)}$$

where  $e$  is eccentricity of the orbit ( $0 < e < 1$ ) and  $r_0$  is called the latus rectum.

The velocity  $\vec{v}$  of the satellite in polar coordinates can be written as

$$\vec{v} = v_r \hat{r} + v_t \hat{\theta} = \dot{r} \hat{r} + r \dot{\theta} \hat{\theta}$$

where  $v_r = \dot{r}$  is the “radial” speed and  $v_t = r \dot{\theta}$  is the “tangential” speed.

Make schematic plots of the speeds  $v_r$  and  $v_t$  as functions of  $\theta$  over one full orbit. Mark any significant points in the plots in terms of  $a$ ,  $e$ , and other variables.

- (b) [1.5 marks] Obtain an expression for the total energy ( $E$ ) of the orbiting satellite in terms of  $a$  and other constants.
- (c) [1 marks] Plot the kinetic energy (KE) of the satellite as a function of  $\theta$  over one full orbit. Mark any significant points in terms of  $a$ ,  $e$ , and other variables.
- (d) [1.5 marks] The perigee and apogee of the elliptical orbit in part (a) are 200 km and 36500 km, respectively. It is generally described as a  $(200 \times 36500)$  km orbit. Here the distances are defined from the surface of the Earth. Calculate the period of rotation  $T$  (in hr) of *Chandrayaan-3* in this orbit.
- (e) [2.5 marks] To move *Chandrayaan-3* from the first orbit (in part (d)) to another elliptical orbit EBN-1, an instantaneous boost was applied at perigee by changing the velocity by  $\Delta v$ , without altering the direction. This changed the apogee to 41800 km above Earth's surface while keeping the perigee unchanged. Calculate  $\Delta v$ .
- (f) [1.5 marks] After a series of manoeuvres, *Chandrayaan-3* was placed in an elliptical orbit of  $(100 \times 1437)$  km around the Moon. Here, the distances are calculated from the surface of the Moon. Calculate the change in velocity  $\Delta v'$ , applied at the perigee, that is required to bring *Chandrayaan-3* from this elliptical orbit to a circular orbit at a distance of 100 km from the surface of the Moon. For this part, assume that *Chandrayaan-3* is only under the influence of the Moon's gravitational field.

#### 4. Mag-Grav Tussle

A rectangular conducting loop of mass  $m$ , width  $w$ , length  $h$ , and self inductance  $L$  is held in the vertical  $x$ - $y$  plane with its bottom edge along the  $y$ -axis (see figure on the left below). In this problem take the resistance of the loop to be zero. A uniform magnetic field  $\vec{B}$  is applied horizontally as shown in the figure such that

$$\begin{aligned}\vec{B} &= B\hat{k} & \text{for } x \leq 0 \\ &= 0 & \text{for } x > 0\end{aligned}$$

The loop is released from rest at time  $t = 0$  and descends under gravity (see the figure to the right below). The acceleration due to gravity  $g$  is in  $+x$  direction.

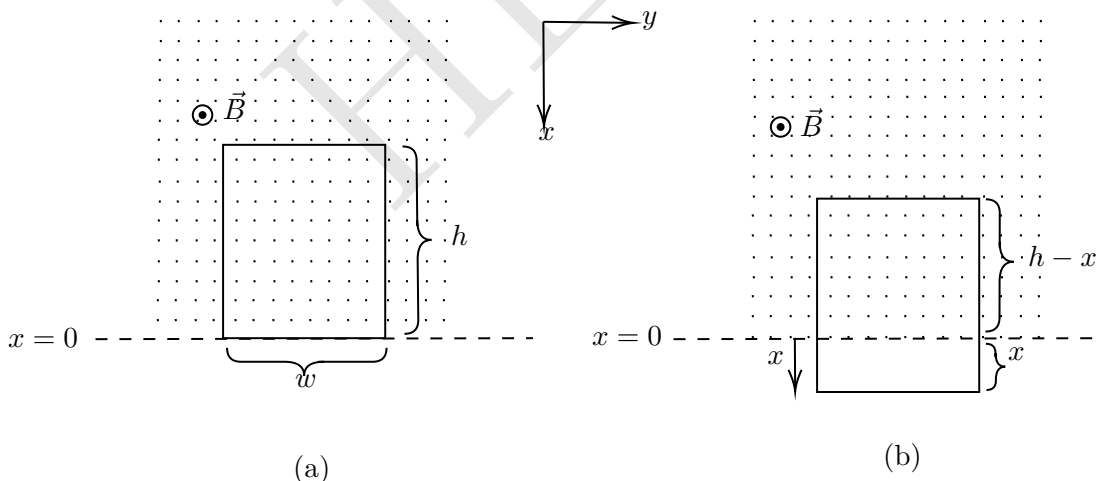

- (a) [5 marks] Obtain  $x(t)$ , the position of the bottom edge of the loop at time  $t$ , in terms of relevant variables.
- (b) [6 marks] Imagine different possible scenarios for the nature of motion of the loop and plot  $x(t)$  for each.

#### 5. Thermal Tussle

Consider a horizontal insulated cylindrical tube of very large length. Two identical insulated pistons, each of mass  $M = 0.2$  kg are fitted within the tube separated by a length  $L_0 = 1$  m. The space between the two pistons is filled with one mole of (ideal) helium gas, initially at temperature  $T_0 = 300$  K. The external pressure, everywhere outside the pistons and tube, is zero.

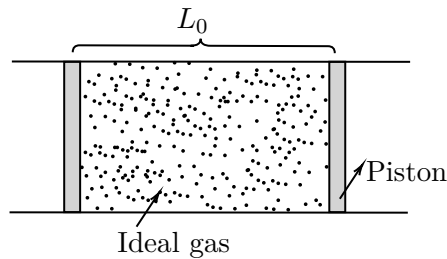

Initially, the pistons are held in place by an external mechanism. At time  $t = 0$ , the mechanism is released and the pistons move without friction and the process is quasistatic initially. Assume that the gas behaves ideally throughout. Let  $C_p$  and  $C_v$  be the specific heats of the gas at constant pressure and volume respectively. Also,  $\gamma = C_p/C_v = 5/3$ .

- (a) [6 marks] Determine the velocity ( $v_p$ ) of each piston in terms of the gas temperature  $T$  and other relevant variables. At what temperature ( $T_c$ ), is the process no longer quasistatic? Calculate  $T_c$ .
- (b) [4 marks] From here, we restrict our analysis only to the quasistatic regime of the process. We define  $u = T/T_0$ . Obtain the relation between  $u$  and  $t$  in the following form

$$t = f(u)$$

You may leave the answer in terms of a suitable integral involving  $L_0$ ,  $M$  and other variables.

- (c) [4 marks] Qualitatively plot the rate of change of temperature ( $dT/dt$ ) vs  $T$ . Mark any significant point(s) on the temperature axis in the plot.
- (d) [4 marks] At what time  $t$  does the temperature  $T$  of the gas reach 20K? What is the piston velocity ( $v_p$ ) at this point?

## 6. Sonic Sleuth

During her summer vacation, Dheera decides to carry out a smartphone based experiment. She utilizes a smartphone's frequency sensor that can measure the frequency of the audio signal it receives. She takes a long cylindrical tube closed at one end. This tube has a length of  $L = 30.0$  cm and an inner diameter of  $d = 2.45$  cm. Dheera starts filling the tube with water, which is dripping from a tap at a constant rate  $Q$  (measured in milliliters per second (mL/s)).

Dheera positions her smartphone near the open end of the tube to measure the frequency of the sound emitted as water fills the tube. An app on the phone captures a range of frequencies in the recorded audio at any given time. At randomly chosen values of time  $t$ , one of the frequencies at that time is shown in the following table.



Time $t$ (s)	Frequency $f$ (Hz)	Time $t$ (s)	Frequency $f$ (Hz)
5.0	915	36.0	434
7.6	320	39.6	481
16.2	345	41.9	500
16.7	1008	42.5	1454
20.9	360	51.1	1618
25.7	1148	51.6	574
28.9	1196	56.1	1782
31.5	410	60.2	680
33.3	1290	66.3	820

Help her to analyse the experiment.

- (a) [3 marks] Derive the expression for the velocity of sound  $c_s$  in terms of  $f, t$ , and constants.
- (b) [8 marks] Choose a pair of suitable variables and plot a linear graph. Specify the axis labels. Obtain the speed of sound  $c_s$  and the rate  $Q$  from this plot.

---

\*\*\*\* END OF THE QUESTION PAPER \*\*\*\*

HBCSE



Space for rough work — will NOT be submitted for evaluation

HBCSE