

# Indian National Junior Science Olympiad (INJSO) – 2023

conducted jointly by

Indian Association of Physics Teachers (IAPT)

and

Homi Bhabha Centre for Science Education (HBCSE-TIFR)

## Question Paper

Roll Number:     -     -

Duration: **Three Hours**

Date: 28<sup>th</sup> January 2023

Maximum Marks: 180

*Please Note:*

- Please write your roll number in the space provided above.
- Use of non-programmable scientific calculators is allowed.
- **The answer-sheet must be returned to the invigilator.** You can carry this question paper with you.
- Section I of this question paper has 15 questions.
  - For each question in this section, **only one** of the four options is a correct answer.
  - For each question, a correct answer will earn 3 marks, a wrong answer will earn (–1) mark, and an unattempted question will earn 0 marks.
  - If you mark more than one option, it would be treated as a wrong answer.
- Section II contains 9 questions worth 5 marks each. There is no negative marking.
  - For each of these questions one or more option(s) may be correct.
  - You will get full credit for each question only if you mark all correct options **and** no wrong option. There are no partial marks for these 9 questions.
- Section III contains 11 questions.
  - For all the questions in this section, the process involved in arriving at the solution is more important than the final answer. Valid assumptions / approximations are perfectly acceptable. Please write your method clearly, explicitly stating all the reasonings / assumptions / approximations.
  - In case you fall short of writing space for any question, you can ask for an extra sheet. You can ask for maximum of two extra sheets.

**Happy Solving**

### Useful Constants

Gravitational constant	$G \approx 6.674 \times 10^{-11} \text{ N m}^2/\text{kg}^2$
Gravitational acceleration	$g \approx 10 \text{ m/s}^2$
Mass of electron	$m_e \approx 9.109 \times 10^{-31} \text{ kg}$
Charge of an electron	$e \approx 1.602 \times 10^{-19} \text{ C}$
Avogadro constant	$N_A \approx 6.022 \times 10^{23}/\text{mol}$
Specific heat capacity of water	$s = 4.2 \text{ J}/(\text{g } ^\circ\text{C})$
Density of water	$\rho_w = 10^3 \text{ kg/m}^3$
Universal gas constant	$R \approx 8.3145 \text{ J}/(\text{mol K})$
Atmospheric pressure	$1 \text{ atm} \approx 101\,325 \text{ Pa}$
Molar volume of gas at STP	$V_{STP} \approx 22.4 \text{ L}$
Molar volume of gas at 1 atm and $100^\circ\text{C}$	$V_{100} \approx 30.6 \text{ L}$
Permittivity of free space	$\epsilon_0 \approx 8.854 \times 10^{-12} \text{ C}^2\text{N}^{-1}\text{m}^{-2}$
Radius of the Earth	$R_\oplus \approx 6400 \text{ km}$
Radius of the Moon	$R_{moon} \approx 1700 \text{ km}$

Element	Atomic Number	Atomic Mass	Element	Atomic Number	Atomic Mass
H	1	1.0	Cl	17	35.5
C	6	12.0	K	19	39.0
N	7	14.0	Ca	20	40.0
O	8	16.0	Fe	26	56.0
Na	11	23.0	Zn	30	65.4
Al	13	27.0	Ag	47	107.9
S	16	32.0	Au	79	197.0

## Section I: Single Correct MCQ

1. One of the major challenges in creating “Dolly” the first cloned organism/animal, was the process of creating an enucleated egg (nucleus removed), as the artificial removal of the nucleus damaged the egg cell. The cloning of Dolly in 1996 was achieved by inserting the nucleus of a mammary epithelial cell, precisely into such an enucleated egg cell. If you were to choose to activate a naturally occurring molecular mechanism of enucleation in an egg cell, which of the following cell type would you study to mimic the mechanism?
- A. Neurons / Neuroblasts
  - B. Erythrocytes / Erythroblasts**
  - C. Muscle cell / Myoblasts
  - D. Bone tissue cells / Osteoblasts

**Solution:**

Answer: RBCs do not contain nuclei as they eject their nucleus during maturation of RBC, students will need to connect that this is a biologically naturally occurring process where cells lose their nuclei. Hence that is the cell type to be studied

2. Which of these phenomena has not yet been observed in wild chimpanzees?
- A. Demonstration of the ability to use stone and/or wooden tools
  - B. Demonstration of the ability to use of fire to process food**
  - C. Demonstration of the ability to communicate using primitive language
  - D. Demonstration of ability to grieve in groups at the death of a member

**Solution:**

Answer: This information is based on contemporary literature, where several news articles have reported the finding that primates seem to mourn their dead and similar behavior has been recorded before in elephants and some birds. The use of fire has only been noticed in rare captive/zoo primates or those who closely interact and therefore mimic activities by humans like roasting marsh-mellows on campfire. This therefore tests the students general knowledge about human evolution, particularly in light of the Nobel Prize 2022.

3. Some microbes produce diffusible metabolites that can be used by other microbes for their growth. Three such microorganisms were tested for their nutritional growth requirements (under +/- light, scheme below) either on minimal salt media (lacking any organic sources of carbon and nitrogen) OR on complete or rich media containing salts with organic carbon and nitrogen.

Based on the growth patterns shown after 24hrs, pick the correct option:

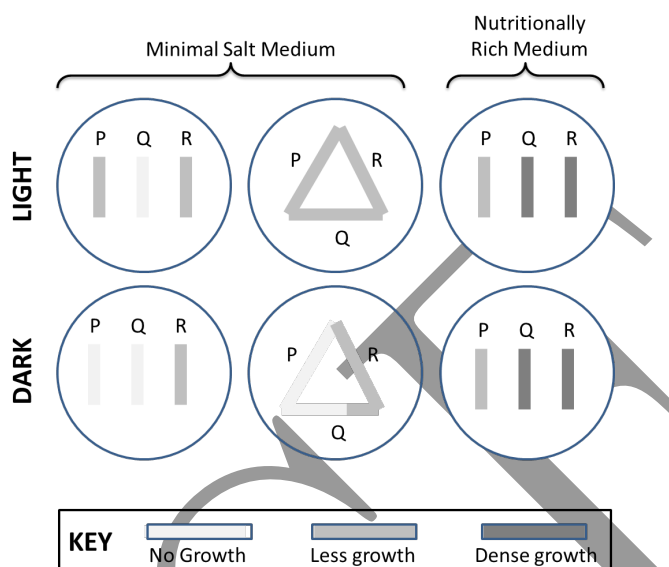

- A. P - Autotrophs, Q - Heterotroph, R - Heterotroph  
 B. P – Photoautotroph, Q – Chemoheterotroph, R - Chemoautotroph  
 C. P - Chemoautotrophs, Q - Chemoautotrophs, R – Heterotroph  
 D. P - Photoautotroph, Q - Chemoheterotroph, R - Saprophyte

**Solution:**

Portion has Autotroph and Heterotroph, but students will need to read about Nutritional requirements of microorganisms – i.e. photo/chemo/organo, we will be giving them a paragraph to read about the same as an addendum to their portion

4. A breed of dogs show Black, Chocolate, and Golden coat colors due to the interaction of products of two genes, one that produces pigment and another that distributes the pigment to hair follicles. The final coat color is due to the interaction of products of these two genes. In this kind of gene interaction, the alleles of one gene in homozygous recessive condition masks/suppresses the expression of the allele of another gene either in dominant or recessive state. This kind of interaction is known as the epistasis. The gene that masks the expression

is epistatic and the one that gets masked is hypostatic. Assume that the allele that produces pigment is represented by 'A', so the 'a' would be the allele that cannot produce pigment and the allele that is responsible for pigment distribution is 'B' and the allele that is responsible for reduced distribution is 'b'.

Now, consider the following pictorial demonstration of a cross. Which of the following ratios will be obtained in the F2 progeny due to this kind of interaction?

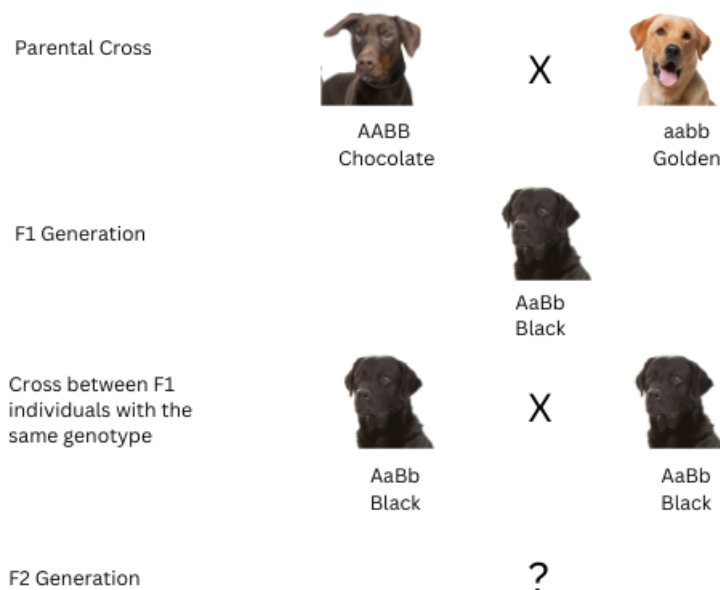

- A. 9:3:4 (Black:Chocolate:Golden)
- B. 12:3:1 (Black:Chocolate:Golden)
- C. 15:1 (Chocolate:Golden)
- D. 9:6:1 (Chocolate:Black:Golden)

**Solution:**

In the recessive epistasis, the recessive alleles of one gene when in homozygous state, do not allow the other gene to express and hence the last two phenotypic categories have the same phenotype and the resultant ratio is 9:3:4(3+1)

5. Movement of ions in and out of guard cells in plants is responsible for the stomatal activity (i.e. opening and closing of stomata). An experiment was carried out on two broad bean plants (Plant I and II) using a radioactive isotope of potassium. The concentration of potassium ions in the two guard cells of each plant was measured using a radioactivity counter. The graph below shows the  $K^+$  concentration (indicated as potassium X-ray counts per sec) in each of the guard cells in respective plants, I and II. Based on the results, which of the following is true?

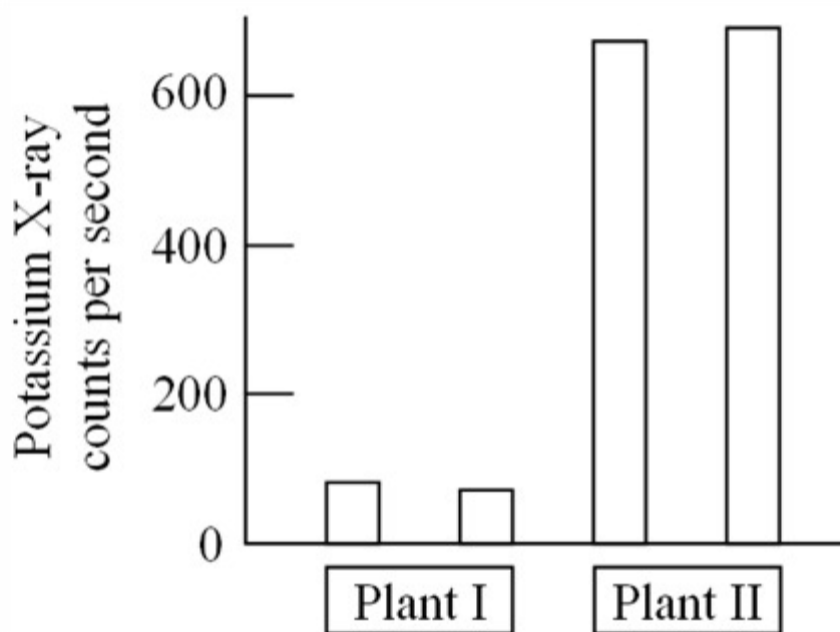

- A. I has open stomata most likely for transpiration.  
**B. II has open stomata most likely due to exposure to light.**  
 C. II has open stomata most likely due to absence of light.  
 D. I has open stomata for uptake of carbon dioxide.

**Solution:**

Ref: Life Science of Biology – Sadava - 5th edition – Page 774 – pdf page 810 Explanation:  
 I - stoma closed II - stoma open  $K^+$  concentration within the guard cells around an open stoma was much greater than that in the guard cells of a closed stomata.

6. Two salts **X** and **Y** are heated strongly in two test tubes separately to study their decomposition process, and following observations are made during the experiments.
- Salt **X** evolves gases that are acidic in nature.
  - One of the evolved gases from salt **X** helps in burning of a candle.
  - A yellow-colored residue is formed after complete decomposition of salt **X**.
  - Salt **Y** completely decomposes to produce gases.
  - Salt **Y** generates a gas that makes you laugh.

The salts **X** & **Y**, respectively, are ...

- A. Zinc carbonate & Silver nitrate  
 B. Ammonium carbonate & Barium nitrate  
**C. Lead nitrate & Ammonium nitrate**  
 D. Potassium iodide & Sodium nitrate

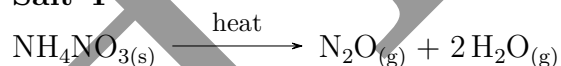
**Solution:****Salt X****Salt Y**

7. Wood pulp contains multiple compounds, including several polymers. Hydrolysis of one of the polymers produces compound  $\alpha$ . This compound  $\alpha$  undergoes anaerobic decomposition by microbes and produces compounds  $\beta$  and  $\gamma$ .

Compounds  $\alpha$ ,  $\beta$  and  $\gamma$ , respectively, are;

- A. Cellulose, ethanol, water  
**B. Glucose, ethanol, carbon dioxide**  
 C. Lactose, lactic acid, carbon dioxide

D. Starch, ethanoic acid, carbon dioxide

**Solution:**

Acid hydrolysis of wood pulp produces **glucose** [ **monosaccharide** ]

**Glucose** on anaerobic decomposition produces compounds ethanol or methane and carbon dioxide.

8. Read the statements given below:

- (i) Dissolution of glucose in water is an exothermic process.
- (ii) Mixing of calcium oxide in water is an endothermic process
- (iii) Melting of ice into water is an endothermic process.
- (iv) Dilution of sulphuric acid in water is an endothermic process.
- (v) Boiling of water is an exothermic process.

Of the above, the true statement/s is/are:

- A. (iii)    B. (v) and (i)    C. (iv) and (v)    D. (i), (ii), and (iv)

**Solution:**

During melting of Ice heat is absorbed from the surroundings.

9. Find the number of moles of hydrogen gas liberated when 39 g of potassium is treated with 7.8 g of water.

- A. 0.22 mol    B. 0.43 mol    C. 0.50 mol    D. 1.0 mol

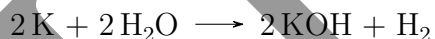
**Solution:**

39 g of potassium = 1 mol ;

7.8 g of water = 0.433 mol

10. A closed container has a mixture of 48 g of sodium hydroxide, 52 g of water and 132 g ammonium sulphate. Find the number of moles of oxygen atoms present in that container

- A. 5    B. 7    C. 8    D. 10

**Solution:**

Moles of Oxygen atom in the container

= Moles of NaOH + Moles of H<sub>2</sub>O + 4 [Moles of (NH<sub>4</sub>)<sub>2</sub>SO<sub>4</sub> ]

= 1.2 + 2.8 + 4 = 8

11. Angular size of an object is the angle subtended by that object for that distance and size. From the surface of the Earth, the Sun and the Moon appear to be of the same size, because both subtend nearly the same angle at the surface of the Earth.

If someone observes the Moon from the equator of the Earth, it takes nearly 2 minutes for the full disc of the Moon to sink below the horizon. Angular size of the Earth, when observed from the Moon is nearly ...

- A.  $0.5^\circ$    B.  $1^\circ$    C.  $1.5^\circ$    D.  $2^\circ$

**Solution:**

As we need to get approximate answer, we can neglect radii of the Earth and the Moon in comparison with the distance  $r$  between the two. From the Earth, the circumference of  $2\pi r$  is covered in 24 hours = 1440 minutes, while diameter of the Moon (3400 km) is covered in 2 minutes.

$$\begin{aligned}\therefore \frac{2\pi r}{1700} &= \frac{1440}{2} \\ \therefore r &\approx 3.8 \times 10^5 \text{ km}\end{aligned}$$

It means, a distance of  $2\pi r$  from Moon subtends angle of  $360^\circ$ . Thus, angle subtended by diameter of the Earth (12800 km) will subtend an angle

$$\theta = \frac{12800}{2\pi r} \times 360^\circ = \frac{12800}{2\pi(3.8 \times 10^5)} \times 360^\circ \approx 1.9^\circ$$

12. Two identical iron balls of mass 10 g each are moving in space at speeds 10 m/s and 5 m/s along the same direction with the faster one following the slower one. The balls collide, stick together, and continue to move as a single object. The loss of kinetic energy during collision increases the temperature of the combined object. Rise in temperature of the combined object is roughly ...

Note:

- Specific heat capacity of iron is 451 J/(kg K).
- Neglect any other process that may change the temperature.
- Initial temperature of both the balls is assumed to be the same.

- A. 0.007 K   B. 0.014 K   C. 0.07 K   D. 0.14 K

**Solution:**



$$\begin{aligned}
 m_1 &= m_2 = m = 10 \text{ g} = 0.01 \text{ kg} \\
 u_1 &= 10 \text{ m/s}, \quad u_2 = 5 \text{ m/s} \\
 mu_1 + mu_2 &= 2mv \\
 \therefore v &= \frac{u_1 + u_2}{2} = 7.5 \text{ m/s} \\
 \text{Initial K.E.} &= \frac{1}{2}mu_1^2 + \frac{1}{2}mu_2^2 = \frac{1}{2}m(u_1^2 + u_2^2) = 62.5 \times 10^{-2} \text{ J} \\
 \text{Final K.E.} &= \frac{1}{2}(2m)v^2 = 56.25 \times 10^{-2} \text{ J} \\
 \therefore \text{Loss in K.E.} &= 6.25 \times 10^{-2} \text{ J} \\
 \therefore 2m \cdot c \cdot \Delta\theta &= 6.25 \times 10^{-2} \text{ J} \\
 \therefore 2 \times 10^{-2} \times 451 \times (\Delta\theta) &= 6.25 \times 10^{-2} \text{ J} \\
 \therefore (\Delta\theta) &\approx 0.007 \text{ K}
 \end{aligned}$$

13. A car X starts moving with initial velocity  $u$  and acceleration  $a$ . Simultaneously from the same point, another car Y moves in the same direction with initial velocity  $u/2$  and acceleration  $2a$ . All velocities and accelerations are in the same direction. Which of the following is true?
- Cars X & Y will have the same speed when car Y overtakes car X.
  - Cars X & Y will have the same speed at some instance, but car Y will overtake car X at different instance.**
  - Cars X & Y will have the same speed at some time but will never cross each other.
  - Car Y will overtake car X but the two will never have the same speed.

**Solution:**

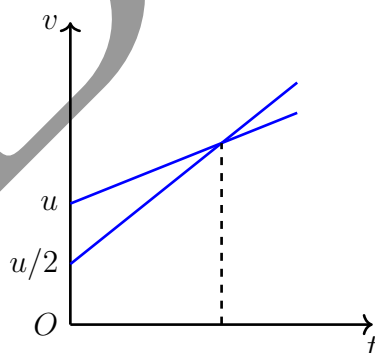

The area under each line gives the total displacement of the car. The cars will overtake each other when the area under both lines are equal. The point of intersection of two lines is the instance when velocities are equal. Clearly, when velocities are equal, the total displacement of each car is different.

As line for second car crosses the first line, there will be some instance, where area under

both lines will be equal. Thus, the car Y will overtake car X, but that is a different instance than the time when the speeds are equal.

14. A thin convex lens forms real image of an object on a screen. If you add another thin lens, in contact with the convex lens, it is now observed that a real image is formed at a longer distance. Which of the following statements is correct?
- The new lens added is a convex lens with a shorter focal length than the first lens.
  - The new lens added is a convex lens with a longer focal length than the first lens.
  - The new lens added is a concave lens with a shorter focal length than the first lens.
  - The new lens added is a concave lens with a longer focal length than the first lens.**

**Solution:**

New image is farther, i.e., rays are diverged by the second lens. Hence it should be concave. Image is still real, i.e., net effect is still that of a converging lens. Hence new concave lens is less diverging, thus of greater focal length.

15. Evaporation of water, in the form of sweat is an essential mechanism in human beings for maintaining normal body temperature. For human body, the specific heat capacity is  $3.5 \text{ kJ}/(\text{kg K})$  and heat of vaporization of sweat at body temperature of  $37^\circ\text{C}$  is nearly  $2.3 \text{ MJ/kg}$ .

On consuming a certain prescribed diet, the body temperature of Balvinder of mass  $82 \text{ kg}$  is expected to increase by  $2^\circ\text{C}$ . To prevent this, Balvinder drinks  $N$  bottles of mineral water ( $250 \text{ mL}$  water in each) kept at ambient temperature ( $37^\circ\text{C}$ ). Assume that the entire amount of this water is converted into sweat, which vaporizes.  $N$  is nearly ...

- A. 1    B. 2    C. 3    D. 4

**Solution:**

$$M_B \cdot s \cdot d\theta = m_w \cdot L = N \cdot V \cdot \rho_w \cdot L$$

$$\therefore N = \frac{82 \times (3.5 \times 10^3) \times 2}{(250 \times 10^{-6}) \times 10^3 \times (2.3 \times 10^6)} = \frac{0.82 \times 2.8}{2.3} \approx 1$$

## Section II: Multiple Correct MCQ

16. A food chain and a food web from ecosystems 1 and 2 are represented below.

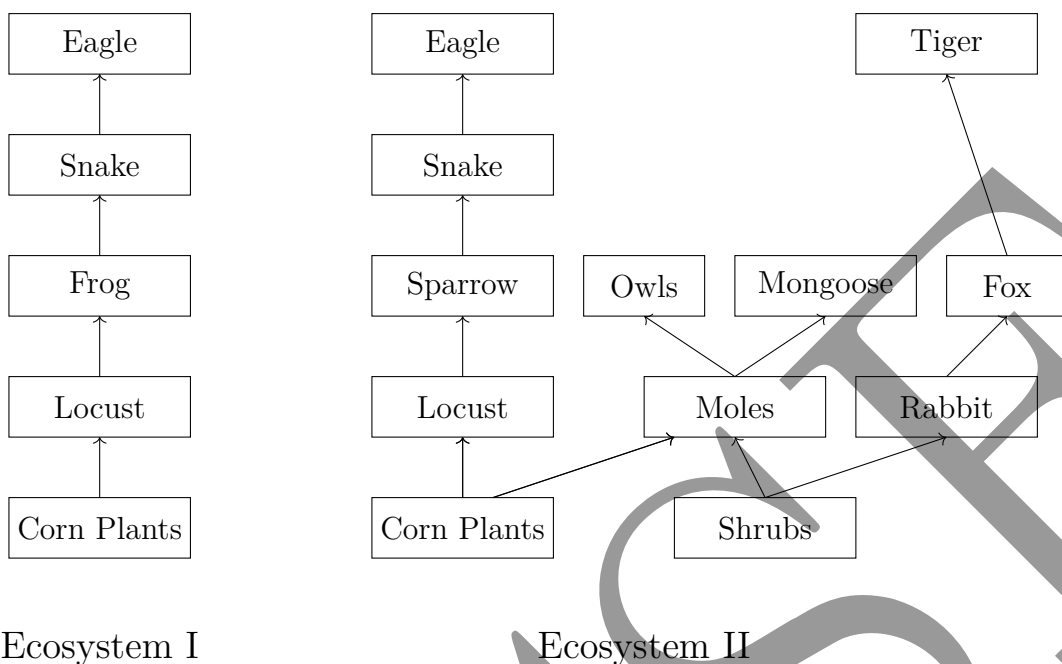

Consider the two pyramids shown below and from the options, identify what they would represent:

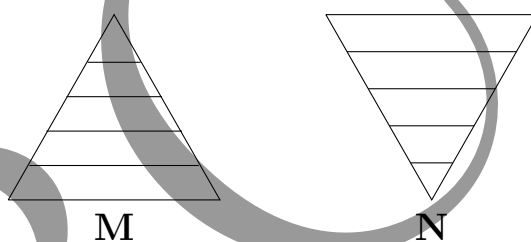

- A. M could be the number pyramid of food web 2 while N could be the number pyramid of food chain 1
- B. M could be the energy pyramid of food web 2 and N could be the energy pyramid of food chain 1.
- C. M could be the number pyramid as well as energy pyramid for food chain 1.
- D. M could be the number pyramid as well as energy pyramid of food web 2.

**Solution:**

Ref: Class X – Pg 258 – 259 Number pyramid in these cases is always upright as the crops are small plants and shrubs that support many numbers of herbivores and carnivores in the ecosystem. The Energy pyramid will also always be upright as the energy cannot be created out of nothing (or lesser at the base of the pyramid).

17. In the laboratory, bacteria are grown in a liquid nutrient medium. They reproduce asexually by successive cycles of binary fission. When such populations are grown in a flask, bacteria show a predictable growth pattern known as a growth curve. The following graph represents such a typical growth curve with the different phases of growth, as indicated.

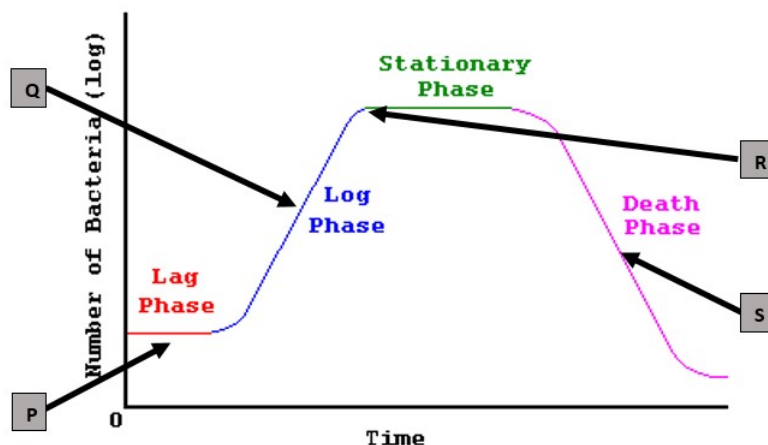

Choose the correct option(s) that describe(s) the condition for each annotated point on the graph:

- (i) Lowest concentration of nutrients, highest growth rate
  - (ii) Highest number of bacterial cells, lower concentration of nutrients
  - (iii) Lowest number of dividing bacterial cells, slow growth rate
  - (iv) Highest growth rate, lesser toxic by-products
  - (v) Highest concentration of nutrients, highest number of bacterial cells
  - (vi) Highest concentration of nutrients, low numbers of bacterial cells
  - (vii) Highest concentration of toxic by-products, least number of dividing bacterial cells
- A. p-(vii) q-(iv) r-(ii) s-(iii)  
 B. p-(vi) q-(i) r-(vii) s-(iii)  
 C. **p-(vi) q-(iv) r-(ii) s-(vii)**  
 D. p-(vi) q-(ii) r-(iii) s-(vii)

18. In temperate regions, woody plants undergo dormant condition to adapt to the extreme winter season. Physiologically they show periodic changes in the cellular activity. For example, cambium tissue is actively dividing in normal conditions. During winter dormancy, cells show changes in the protoplasm, their metabolic activity and cellular content. Which of the following feature/s can be seen in dormant cambium cell as compared to actively dividing cell.
- A. **Very few golgi bodies**
  - B. **Lesser amount of rough endoplasmic reticulum**
  - C. Large vacuole occupying much of the cell volume.
  - D. Increased hydration of cellulose microfibrils of the cell wall.

**Solution:**

As cells become dormant they slow down their metabolic capacity. Ultrastructurally this leads to reduction in both Golgi (vesicles and membrane production) and reduced protein synthesis (loss of rough ER – ribosomes).

19. Following table gives information on naturally occurring stable isotopes of three elements and the number of neutrons in these isotopes. Identify the position for the elements in the Modern Periodic Table. Select the correct option/s.

Element Code	Number of stable Isotopes	Atomic mass (a.m.u.)	Number of neutrons
$\alpha$	2	120.90	70
		122.90	72
$\beta$	5	69.92	38
		71.92	40
		72.92	41
		73.92	42
		75.92	44
$\gamma$	2	106.90	60
		108.90	62

- A. Element  $\alpha$  belongs to group 15 and period 5, Element  $\beta$  belongs to group 4 and period 4
- B. Element  $\beta$  belongs to group 14 and period 4, Element  $\gamma$  belongs to group 1 and period 5
- C. Element  $\alpha$  belongs to group 14 and period 5, Element  $\beta$  belongs to group 13 and period 4
- D. Element  $\alpha$  belongs to group 15 and period 5, Element  $\gamma$  belongs to group 11 and period 5**

**Solution:**

Element  $\alpha$  has atomic number 51, hence electronic configuration 2, 8, 18, 18, 5. Thus, it belongs to group 15, period 5.

Element  $\beta$  has atomic number 32, hence electronic configuration 2, 8, 18, 4. Thus, it belongs to group 14, period 4.

Element  $\gamma$  has atomic number 47, hence electronic configuration 2, 8, 18, 18, 1. Thus, it belongs to group 11, period 5.

20. With a solution of  $I_{(aq)}^-$ , chlorine ( $Cl_2$ ) would react more vigorously at similar conditions and concentrations than bromine ( $Br_2$ ) because,
- A. atomic radius of bromine atom is larger than chlorine atom.**
- B. electronegativity of bromine is greater than chlorine.
- C. shielding of nuclear charge within the chlorine atom is less than that in bromine atom.**
- D. nuclear charge in chlorine atom is less than that in bromine atom.

**Solution:**

Both chlorine and bromine need to accept an electron into their outer electron shell to complete the shell during the reaction and form chloride and bromide ions.

21. A member of alkene series **X** has a molecular mass 28 amu. A small quantity of **X** ( $150 \text{ cm}^3$ ) is burnt in just sufficient air (containing 20% oxygen) to form carbon dioxide and steam. If all the measurements are made at 1 atm pressure and  $100^\circ\text{C}$ , then the composition of the products formed and the unreacted air is ...
- A.  $300 \text{ cm}^3 \text{ CO}_2$ ,  $300 \text{ cm}^3$  steam, and  $450 \text{ cm}^3$  the unreacted air, respectively
- B.  $5.9 \times 10^{21}$  molecules of  $\text{CO}_2$ ,  $5.9 \times 10^{21}$  molecules of steam,  $1800 \text{ cm}^3$  the unreacted air, respectively**
- C.  $5.9 \times 10^{25}$  molecules of  $\text{CO}_2$ ,  $5.9 \times 10^{25}$  molecules of steam,  $450 \text{ cm}^3$  the unreacted air, respectively
- D.  $300 \text{ cm}^3 \text{ CO}_2$ ,  $300 \text{ cm}^3$  steam, and  $1800 \text{ cm}^3$  the unreacted air, respectively**

**Solution:**

If a molecular mass of X is 28 amu then the alkene compound is  $\text{CH}_2=\text{CH}_2$

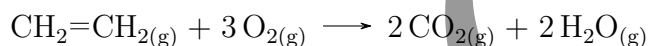

20 % of the air is oxygen, volume of oxygen is  $450 \text{ cm}^3$ . 80 % of the air is unreacted

Molar volume of a gas at  $100^\circ\text{C}$  and 1 atm. Pressure = 30.6 L (Given in data above )

22. A pulse of sound is generated at the centre of a room of rectangular cross section having dimensions  $20 \text{ m} \times 20 \text{ m} \times 30 \text{ m}$ . Speed of sound is 350 m/s. Consider all possibilities of hearing echoes of this pulse. Some of the instances of time when echoes can be detected at the location of the source are ...
- A. 81 ms    B. 86 ms    C. 96 ms    D. 103 ms**

**Solution:**

Let the source be as shown. Reflections are possible from all the points A to Z on the figure.

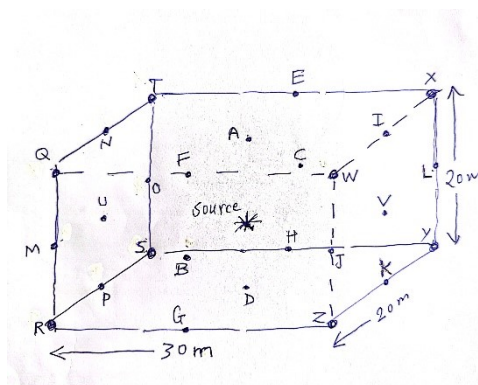

Distances and instances of times of echoes from these points are as given below:

Sr.No	Label of points	Description of points	Distances of echoes	Instances of time of echoes
1	A,B,C,D	Centres of $20 \times 30$ sides	$2 \times 10$ m	57 ms
2	E, F, G, H	Mid points of junctions of $20 \times 30$ sides	$2 \times \sqrt{1+1} \times 10$ m	81 ms
3	I, J, K, L and M, N, O, P	Mid points of all 20 m lines	$2 \times \sqrt{1+2.25} \times 10$ m	103 ms
4	U and V	Centres of $20 \times 20$ sides	$2 \times 15$ m	86 ms
5	Q, R, S, T and W, X, Y, Z	All corner points	$2 \times \sqrt{1+1+2.25} \times 10$ m	118 ms

23. The figure shows an electron projected from O, with velocity  $v$  along the positive X-axis. After a short time, the same electron is found at point A, with its velocity in the plane of the figure. Choose the correct option/s.

- A. The above motion can be due to presence of a uniform electric field along the negative Y direction.
- B. Motion of electron from O to A can be due to presence of a uniform magnetic field perpendicular to XOY plane and outwards.
- C. Motion of electron from O to A can be possible due to presence of both, a uniform magnetic field and a uniform electric field with proper magnitudes and directions.
- D. In the figure given, the path of the electron from O to A will necessarily be along a straight line.

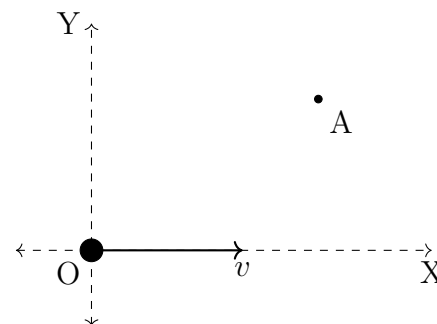

**Solution:**

Force due to electric field is in the direction of electric field for a positive charge and opposite to the electric field for a negative charge.  $\vec{f}_E = q\vec{E}$

Force due to magnetic field can be obtained by using Fleming's left-hand rule.

$$\vec{f}_M = q\vec{v} \times \vec{B}$$

24. Prajakta is riding her cycle on a level road. She applies brake and the cycle slows down. Select the correct statement/s.
- If she applies only the front brake, the force due to both the tyres reduce her cycle's speed.
  - If she applies only the front brake, the force due to ground reduces her cycle's speed.**
  - If she applies only the rear brake, the force due to the rear tyre reduces her cycle's speed.
  - If she applies only the rear brake, the force due to ground reduces her cycle's speed.**

### Section III: Descriptive Questions

25. (8 marks) Four bowls of milk were incubated at room temperature under different conditions (schematic below – either boiled or unboiled milk was mixed and incubated either with a ripe piece of tamarind OR a spoon full of curd). The results of curd formation after 20 hrs is tabulated below, where a number of characteristics are recorded (the more the number of ' + ' signs, the better the firmness of the curd formed, rancid = unpleasant/old taste):

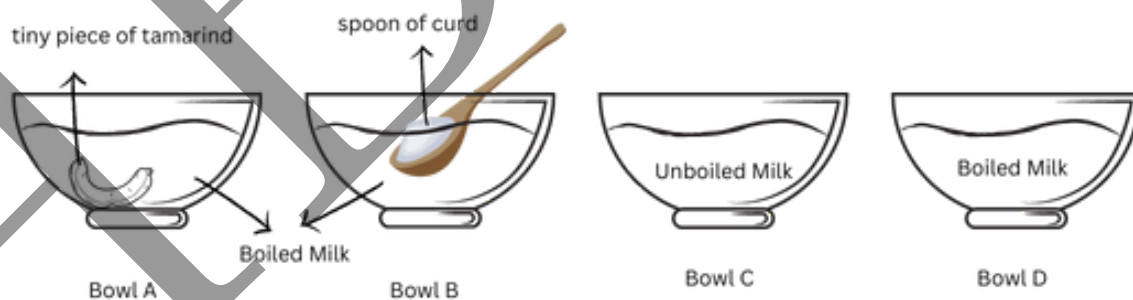

Bowl	Coagulation of milk into curd like solids	Total Acidity	Flavour
A	++	Medium	Good
B	+++	Medium	Great
C	++	High	Rancid smell
D	+/-	Low	Rancid smell



- (a) Based on your knowledge of milk to curd formation, interpret which of the following is true?
- Lactic acid and other bacteria are already present in the milk.**
  - Controlled/desired fermentation of milk occurred in Bowls A, B and C.
  - The spoon of curd introduces lactic acid bacteria into the milk.**
  - Bacteria from the air settled into sample D and prevented curd formation.
- (b) A scientist claimed that the acid from tamarind helped in the curdling of milk. If you were the experimenter and had the option comparing unboiled/untreated samples versus those boiled for 10 min, which of the following observations would help you evaluate that the claim is false:

	<b>Experiment</b>	<b>Outcome</b>
A	The juice/ tamarind extract from that same piece was boiled and added (instead of whole piece)	didn't curdle the milk
B	The juice/tamarind extract from the same piece of tamarind was added directly.	curdled the milk.
C	Tamarind extract was added to the boiled milk sample versus unboiled milk.	resulted in the unboiled milk curdling faster.
D	A raw piece of tamarind added to the boiled milk.	resulted in slower fermentation and curd formation.

**Solution:**

Sample A

- (c) Below are a few facts about the nature of milk and clues to the curdling process:
- Milk is made up of proteins which in turn are made up of amino acids that contain varying amounts of weak acids-COOH and weak bases-NH<sub>2</sub> depending on the amino acid content. These help act like a buffer that resists sudden changes of pH in milk.
  - As bacteria grow in milk, they can either break down these proteins (putrefaction) or utilize lactose to produce acids that contribute to the spoilage of milk.
  - Upon acid accumulation, proteins slowly tend to lose their overall structure, leading to aggregation and coagulation of milk. This is similar to the coagulation of egg albumin protein upon heating.

Based on this and the experiments above, which of the following statements is/are true?

- Milk protein acts like a buffer and hence takes a long time to curdle, as bacterial acids produced, accumulate slowly.**
- Tamarind normally contain bacteria that utilize lactose to produce acids, which accumulate slowly eventually leading to curdling of milk.**
- Weak acids are released from the small piece of tamarind, and take a long time to denature the milk protein that leads to the curdling of milk.
- Tamarind tends to inhibit spoilage of milk as the acids prevent putrefaction of milk proteins due to coagulation.

26. (8 marks) The effects that organisms in a community have on each other are referred to as ecological interactions. Different types of ecological interactions exist based on the types of relationships between the same (intraspecific interactions) or different species (interspecific interactions). Consider the following situations:

**Situation I:** The African buffalo feeds on the grasses growing in the Savannas. The buffalo's hide (skin) is infested with ticks. Oxpecker birds ride on the buffalo and feed on the ticks. While grazing, this large mammal unknowingly destroys insects and their nests present on the ground. These insects which fly around after they are disturbed are eaten by egret birds in the vicinity.

**Situation II:** Carnivores such as timberwolves hunt and kill herbivorous mammals. Grizzly bears in the vicinity attempt to take over the wolf's prey/kill.

**Situation III:** Some kinds of detritivorous mites that need to feed on dung but cannot fly in search of fresh dung attach themselves to the bodies of dung beetles which are not only good at flying but are also good at locating fresh dung.

- (a) For each of the situation (I – III), fill in the table to indicate the various type/s of interaction/s present, where '+' indicates positive effect, '-' indicates negative effect and '0' indicates no effect. Put tick marks (✓) against the appropriate interaction to indicate presence and cross mark (X) to indicate absence.

Serial No.	Effect on species 1	Effect on species 2	Type of interaction	Situation I	Situation II	Situation III
1	+	-	Predation			
2	+	-	Herbivory			
3	0	-	Amensalism			
4	+	0	Commensalism			
5	-	-	Competition			
6	+	-	Parasitism			
7	+	+	Mutualism			

**Solution:**

Serial No.	Effect on species 1	Effect on species 2	Type of interaction	Situation I	Situation II	Situation III
1	+	-	Predation	✓	✓	X
2	+	-	Herbivory	✓	X	X
3	0	-	Amensalism	✓	X	X
4	+	0	Commensalism	✓	X	✓
5	-	-	Competition	X	✓	X
6	+	-	Parasitism	✓	X	X
7	+	+	Mutualism	✓	X	X

- (b) Antagonistic interactions are those in which one species benefits and the other is harmed. Choose the antagonistic interactions from the list of interactions given in the table in Q.26(a) and provide the solution in the answersheet with the corresponding serial num-

bers. Antagonistic interaction/s is/ are:

**Solution:**

1,2 and 6

- (c) Fill in the table below with the type of antagonistic interaction/s observed in each of the situations I, II and III (as referred in the table - Q26a) and also indicate the species/organism that is benefited (indicated by + in the table) and the species that is harmed (indicated by - in the table). Indicate the absence of an antagonistic interaction by writing NONE in the table under the column type of antagonistic interaction.

Situation	Type of antagonistic interaction	Species 1 (+)	Species 2 (-)
I			
Situation	Type of antagonistic interaction	Species 1 (+)	Species 2 (-)
II			
Situation	Type of antagonistic interaction	Species 1 (+)	Species 2 (-)
III			

**Solution:**

Situation	Type of antagonistic interaction	Species 1 (+)	Species 2 (-)
I	Predation	Egrets	Insects
	Herbivory	African buffalo	Grasses
	Parasitism	Ticks	African buffalo
	Predation	Oxpecker birds	Ticks

Situation	Type of antagonistic interaction	Species 1 (+)	Species 2 (-)
II	Predation	Timberwolves	Herbivorous mammals
Situation	Type of antagonistic interaction	Species 1 (+)	Species 2 (-)
III	None		

27. (6 marks) Our body organs are adapted to gravitational force present on earth's surface. Our circulatory system, skeletal system, muscle structure and functions all are adapted according to normal gravitational force on the earth's surface. Longer stay in space results in many physical and physiological changes in human body. Astronauts staying on the International Space Station (ISS) for extended periods of time face changes in regular bodily functions. For example, weight-bearing parts, balancing mechanisms, body fluids do not have to counter gravitational force in microgravity condition.

- (a) Which one of the following changes in circulatory system occur(s) in case of an astronaut staying on ISS?
- Heart shape changes under the influence of microgravity. It gets vertically elongated resulting in increased cardiac output.
  - Longer stay in space leads to gain in ventricular muscle mass as heart has to work harder to pump blood all over the body.
  - Heart rate of an individual on ISS is similar to the rate while lying down on the earth.**
  - Astronaut continuously feel light headedness (dizziness) due to postural hypotension\* during their stay in space but the feeling diminishes after landing on earth.

\*Postural hypotension is a condition of low blood pressure that happens when standing after sitting or lying down.

**Solution:**

Although heart shape does change in space, it becomes more circular. Since gravity no longer pulls blood downwards, overall blood volume accumulates towards the top half of the body (relative to normal gravity conditions) and therefore the heart does not need to pump harder (against gravity) to attain blood flow throughout the body. The blood in the body experiences the same gravitational pull at all points when lying down, and hence that heart rate will be similar to heart-rate in microgravity conditions in space (same level of weightlessness all over). Lastly, when one stands up suddenly from a sleeping position, postural hypotension makes us feel slightly dizzy, hence astronauts will feel dizzier when they land on earth, rather than during their stay in space due to a sudden increase in gravitational influence over the blood flow – a similar reason why astronauts can blackout when ascending in a rocket.

- (b) The skeletal system also gets affected due to microgravity. The functioning of osteoblasts (that make and regulate bone matrix) and osteoclasts (that breakdown and absorb bone

matrix) are programmed as per the gravitational load present on the earth. During prolonged stay on ISS, both these types of cells show altered function. The ‘weightless’ condition results in 2-4% loss of bone matter. Interestingly, 97% of this loss is from part/s like: (Put a tick in correct box/es)

A	Wrist bones (Carpels)	
B	Hip bone	
C	Skull	
D	Rib cage	
E	Vertebral column	

**Solution:**

B and E as they are the major weight bearing structures of the body, due to this answer comes from the initial stem (weight bearing parts, last sentence).

A	Wrist bones (Carpels)	
B	Hip bone	✓
C	Skull	
D	Rib cage	
E	Vertebral column	✓

- (c) The International space station is revolving 400 km above the surface of the Earth. As you might have seen (in some movies or TV), the astronauts feel weightless inside the space station. What is the value of gravitational acceleration due to the earth  $g$  as measured at the space station?

**Solution:**

Let  $R$  be radius of the Earth. According to Newton’s law of gravitation, the gravitational force experienced by an object of mass  $m$ , at an altitude  $h$  from the centre of the Earth, is given by

$$F_G = \frac{GMm}{(R+h)^2}$$

Gravitational acceleration at altitude  $h$  is thus given by

$$g_h = \frac{F_G}{m} = \frac{GM}{(R+h)^2}$$

$$\therefore \frac{g_h}{g} = \left(\frac{R}{R+h}\right)^2 = \left(\frac{6400}{6400+400}\right)^2 = 0.8858 = 88.6\%$$

Weightlessness is experienced due to lack of normal reaction as gravitational acceleration plays the role of centripetal acceleration.

28. (8 marks) A plasmid is an extrachromosomal DNA present in bacteria, imparting them with additional function, for example those imparted by antibiotic resistance genes. In recombinant DNA technology, a foreign gene of interest is usually inserted at a site present within the

antibiotic resistance gene. This helps screen the bacterial cells that contain the engineered recombinant plasmid.

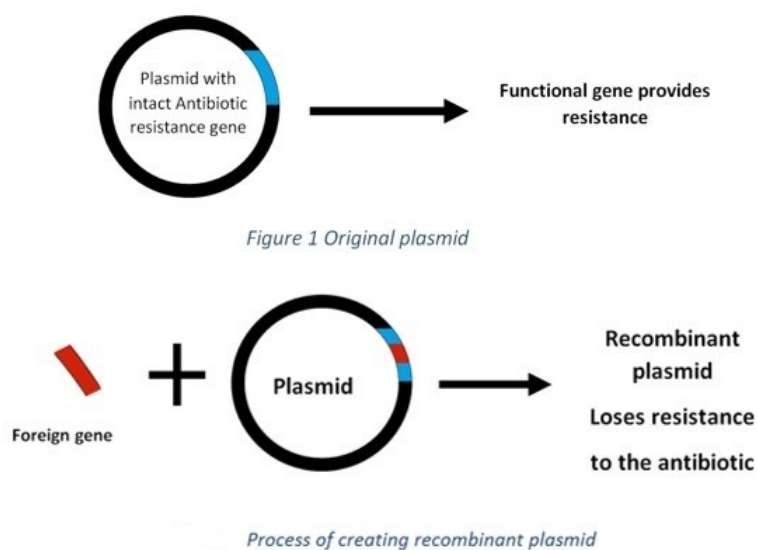

In an experiment, plasmid pBR322 is used, which has both tetracycline (tet) and ampicillin (amp) resistance genes. A foreign gene is inserted in this plasmid at a site present within the tetracycline resistance gene.

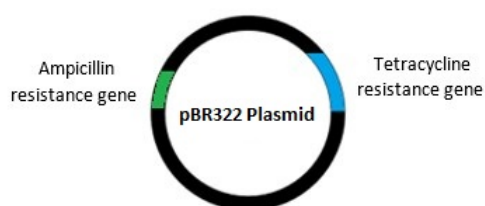

- (a) Bacterial cultures with these recombinant plasmids were grown on solid media plates each containing a different combination of antibiotics. Based on the observations after the growth period, state which of the following statements would be true/false-
- i. Bacterial cells with recombinant plasmid grow on media containing both ampicillin and tetracycline.
  - ii. Bacterial cells with recombinant plasmid grow on media containing ampicillin only.
  - iii. Bacterial cells that lose the plasmid grow on media containing tetracycline only.
  - iv. Bacterial cells with recombinant plasmids will grow on media containing tetracycline only.

**Solution:**

A.False B.True C.False D.False

- (b) Growth of the bacterial culture on ampicillin containing media would not be observed in which of the following cases of the same experiment-

A. A successful recombination where the DNA gets inserted at the expected locus.

- B. A failed recombination where the DNA gets inserted outside both the antibiotic resistance genes.
- C. No recombination at all.
- D. Complete loss of plasmid from all the cells.**

(c) As per the sequential flow of the above experiment, insert the corresponding roman numerals for each of the following statements at the correct places in the diagram below, as shown by the examples in the figure.

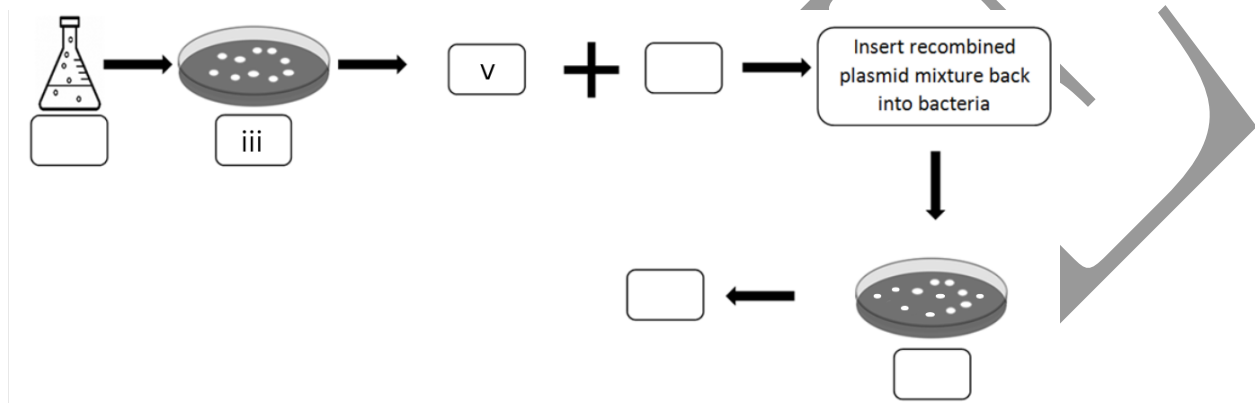

- i. Foreign gene
- ii. Bacterial culture plated on media plate containing ampicillin
- iii. Bacterial culture plated on media containing both ampicillin & tetracycline.
- iv. Bacterial cells with pBR322
- v. Purify plasmid and cut at Tet gene for genetic engineering
- vi. Isolate the bacteria with the desired recombinant plasmid

**Solution:**

iv → iii → v → i → ii → vi

29. (13 marks) Sumeet and Swapnil separately carried out experiments to find out the volume of dilute hydrochloric acid solutions required to react with a sample of 0.57 g of aluminum powder completely.

Sumeet filled a burette with dilute hydrochloric acid up to the zero mark. He placed 0.57 g of aluminum powder into a conical flask and then slowly added the acid until the reaction was complete, indicated by no effervescence. The leftmost panel in the diagram below reveals his burette reading.

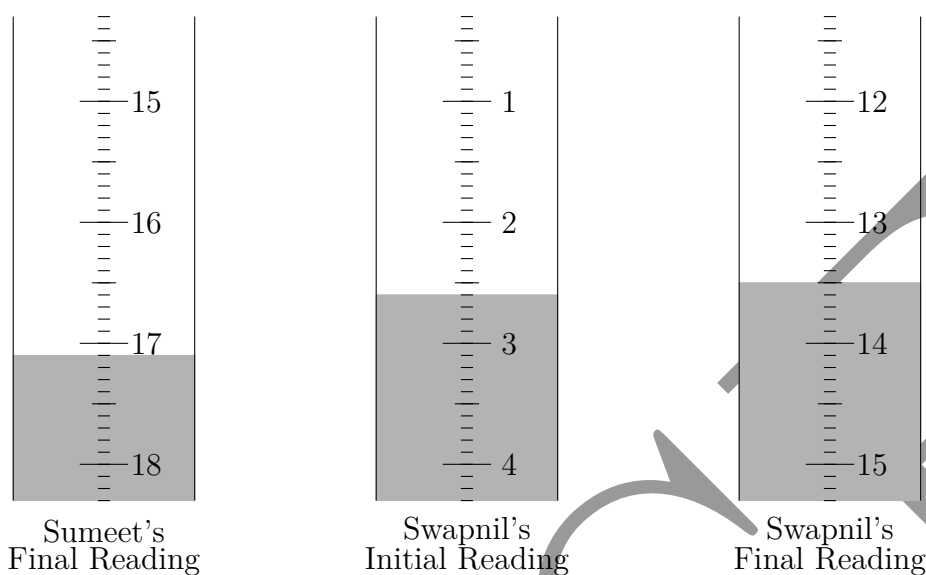

Swapnil repeated the experiment with 0.57 g of Aluminum powder from the same sample source, but with a different sample of dilute hydrochloric acid. The middle panel in the diagram above reveals his initial burette reading and the rightmost panel reveals his final burette reading.

- (a) Write the balanced chemical equation for the reaction between aluminum and hydrochloric acid, stating the physical states of all chemicals.

**Solution:**



- (b) Use the information provided to complete the following table. Record the volumes to the nearest 0.1 cm<sup>3</sup>

Burette reading in mL	Sumeet's Experiment	Swapnil's Experiment
Final burette reading		
Initial burette reading		
Volume of acid added		

**Solution:**

Burette reading in mL	Sumeet's Experiment	Swapnil's Experiment
Final burette reading	17.1 mL	13.5 mL
Initial burette reading	0.0 mL	2.6 mL
Volume of acid added	17.1 mL	10.9 mL

- (c) The concentration of the acid used by Sumeet in the experiment was 3.5 mol/dm<sup>3</sup>. What was the concentration of the acid used by Swapnil for the experiment, if both titrations were done accurately?



**Solution:**

Moles of acid used by Sumeet =  $\frac{17.1 \times 3.5}{1000} \approx 0.0599$  mol

Hydrochloric acid required for the reaction is 0.060 mol

Concentration of the Hydrochloric acid used by Swapnil is,  
 $= \frac{0.0599 \times 1000}{10.9} \approx 5.5$  mol/dm<sup>3</sup>

- (d) After completing the experiment and removing conical flask from tip of the burette, Swapnil observed his burette has started leaking, as he had not properly closed the stopper of the burette. He closed the stopper properly to stop leak and observes reading once again. It was approximately additional 11 % of the volume consumed in reaction earlier. Leaked acid had fallen on the table. To keep table clean, neat and tidy he puts excess Sodium bi carbonate on it. Sumeet checked pH of resultant mixture by pH paper.
- Write complete balanced chemical reaction between hydrochloric acid and sodium bicarbonate.

**Solution:**

- What minimum quantity of sodium bicarbonate (in grams) is required to nullify the effect of spilled acid?

**Solution:**

Approximately,  $\frac{10.9 \times 11}{100} = 1.2$  mL

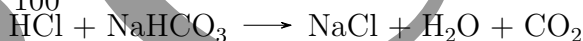

Minimum equimolar quantity of sodium bi carbonate is required for the neutralization of the acid.

Number of moles of HCl =  $5.5 \times 1.2 \times 10^{-3} = 0.0066$  mol ;

Hence number of mole of sodium bi carbonate is the same, 0.0066 mol.

Molar mass of NaHCO<sub>3</sub> = 84

Minimum amount of NaHCO<sub>3</sub> =  $0.0066 \times 84 = 0.554$  g

- Find the percent purity of aluminum sample.

**Solution:**

From the balanced chemical equation

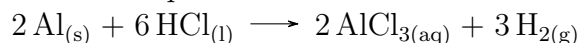

6 moles of hydrochloric acid requires 2 moles of Aluminum for complete reaction.

0.06 moles of hydrochloric acid will react 0.02 moles of Aluminum

Weight of 0.02 moles Aluminum is  $0.02 \times 27 = 0.54$  g Al

% Purity of the metal =  $\frac{0.54}{0.57} \times 100 \approx 95\%$

- (e) To check the process works good on other metals, both took the same amount of sample (0.57 g) of pure Zinc instead of Aluminum and carried out the titration process
- Write balanced chemical reaction, mentioning physical states, between Zinc powder

and Hydrochloric acid.

**Solution:**

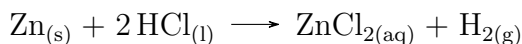

- ii. How many times Sumeet and Swapnil need to dilute their own acid solutions so as to get burette readings for the reaction with Zinc between 10 mL and 15 mL.

**Solution:**

$$0.57 \text{ g Zn} \equiv \frac{0.57}{63.4} = 0.009 \text{ mole of Zn};$$

HCl required = 0.018 mole;

	Sumeet	Swapnil
Burette reading	$\frac{0.018 \times 1000}{3.5} = 5.1 \text{ mL}$	$\frac{0.018 \times 1000}{5.5} = 3.3 \text{ mL}$

To get the reading between 10 mL and 15 mL

Sumeet should dilute the solution **2 times** and

Swapnil should dilute the solution **4 times**

30. (13 marks) Shikimic acid is a natural product extracted from a spice called star anise, commonly used in India. It is a white solid with melting point 186 °C and boiling point 401 °C. It is also a raw material for synthesis of the antiviral drug Tamiflu.

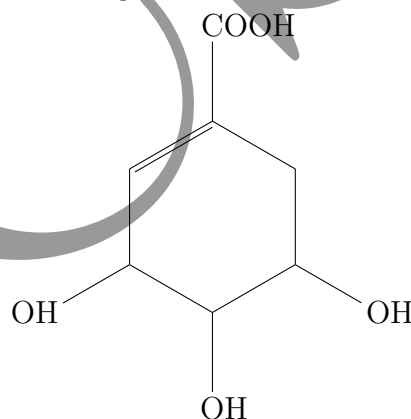

- (a) What is the elemental composition of this molecule in terms of mass percentages?

**Solution:**

Molecular formula can be deduced from the structure  $\text{C}_7\text{H}_{10}\text{O}_5$ .

From the molecular formula one can calculate the mol. Mass = 174 g/mol

Then, find the elemental analysis of the molecule.

$$\text{percentage of C} = \frac{7 \times 12}{174} \times 100 \approx 48.3\%$$

$$\text{Percentage of O} = \frac{5 \times 16}{174} \times 100 \approx 46.0\%$$

$$\text{percentage of H} = \frac{10 \times 1}{174} \times 100 \approx 5.75\%$$

- (b) Shikimic acid (10.0 g) on esterification with ethanol in presence of acid gives compound A (8.5 g). When A was treated with aqueous sodium hydroxide, a new compound B was formed.

i. Give the structure of product A

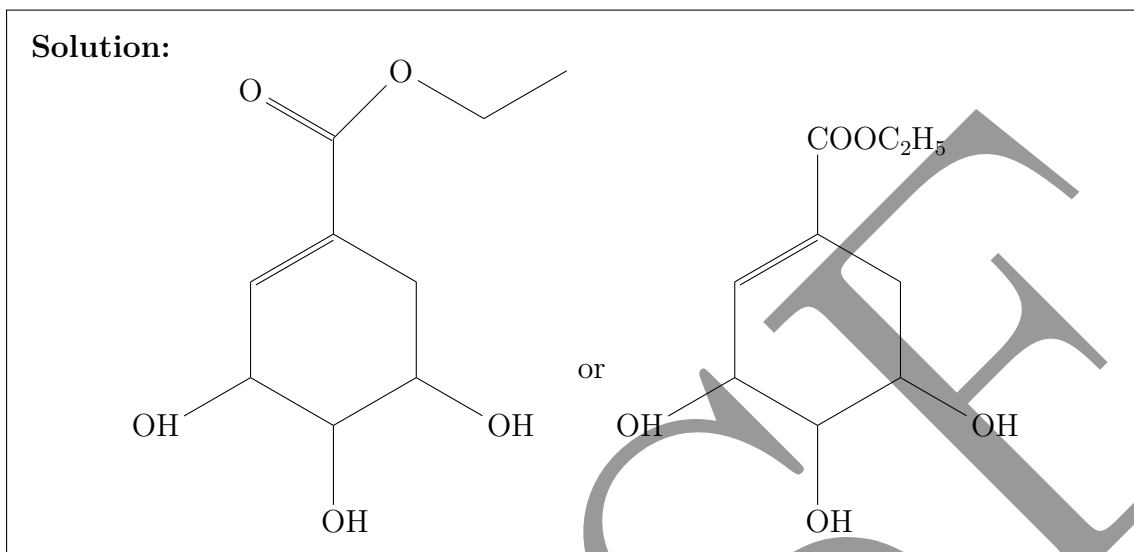

ii. How many C–H bonds are present in the molecule A ?

**Solution:**

11 (eleven)

iii. What happens to the pH value of the reaction mixture as shikimic acid converts to A, will it increase/decrease/remain the same?

**Solution:**

Increase

iv. Practically in many reactions, complete conversion of reactants to products does not happen. The ratio of moles of actual yield versus moles of theoretical expected yield gives the percent yield. Calculate the yield (%) of the product A obtained, based on the data given above.

**Solution:**

S.No.	Weight (g)	Mol.wt. (g/mol)	Moles (mmol)	% Yield
1	10.0	174	57.45	
2	8.5	202	42.08	73.25 %

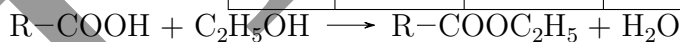

Molecular mass of  $C_6H_6(OH)_3-COOH = 174$

Molecular mass of  $C_6H_6(OH)_3-COOC_2H_5 = 202$

mmol of  $C_6H_6(OH)_3-COOH = 57.45$

mmol of  $C_6H_6(OH)_3-COOC_2H_5 = 42.08$

$57.45 \text{ mmol of } C_6H_6(OH)_3-COOC_2H_5 \approx 100 \%$

$42.8 \text{ mmol of } C_6H_6(OH)_3-COOC_2H_5 \approx 73 \%$

v. Which is more soluble in aqueous solution? Shikimic acid or A?

**Solution:**

Shikimic acid

- vi. Give the general chemical equation for the formation of B.

**Solution:**

$$\text{Ester} + \text{NaOH}_{(\text{aq})} \longrightarrow \text{sodium salt of shikimic acid} + \text{C}_2\text{H}_5\text{OH}$$

OR:

$$\text{R-COOC}_2\text{H}_5 + \text{NaOH}_{(\text{aq})} \longrightarrow \text{R-COONa} + \text{C}_2\text{H}_5\text{OH}$$

- vii. Biryani is loved by many people in India. Star anise is a common flavouring agent for Biryani. Shyama added the whole spices including star anise with rice in water and half cooked it. Then she removed the whole spices from the half-cooked rice and layered the vessel with fried vegetables and again cooked the ingredients on a medium heat.

Tina made the same dish by first boiling rice in water (without star anise) to half cooked stage, added fried vegetable, and then recooked it. Then, she tempered the whole spices (including star anise) in oil, sautéed for a while and added it to the cooked biryani.

In whose Biryani the rice grains would have higher amount of shikimic acid? What property of shikimic acid leads to this difference in amount in the two recipes.

**Solution:**

Shyama's Biryani would have higher amount of shikimic acid

The presence of polar groups like  $-\text{OH}$  and  $-\text{COOH}$  makes shikimic acid highly polar. Also, shikimic acid can form hydrogen bonds with water and hence, will be more soluble in polar solvents like water and less soluble in non-polar solvent i.e., oil in this case

31. (4 marks) As a part of an experiment to study Tyndall effect, Aamir adds sugar to aqueous dispersion of gold nanoparticles of size 100 nm. Once the experiment is completed, he plans to recover gold nanoparticles and use them in another experiment. As he tries to separate gold nanoparticles and sugar, by mistake, he adds the mixture to a tube containing calcium carbonate. This results in a mixture containing gold nanoparticles, sugar, water, and calcium carbonate.

He separates the constituents in three steps by using set of apparatus available in the lab.

Instruments and materials available in the lab: Heater, sublimation set up, beaker, filter paper, funnel, centrifuge, centrifuge tubes, separating funnel, distillation set-up, fractional distillation set-up, and thermometer. Mention the separating methods in the correct sequence he used in order to obtain gold nanoparticles and sugar in their pure form with the least amount of loss. State which component is obtained at every step.

**Solution:**

Methods:

Step 1: Filtration → calcium carbonate is separated.

Step 2: centrifugation followed by filtration or decantation → gold nanoparticles are separated.

Step 3: heating followed by evaporation and crystallization → sugar is separated.

32. (7 marks) A steel ball of mass 100 g is attached to the ceiling of a cabin (of mass 4 kg) with an electromagnet of mass 0.5 kg resting on the upper side, as shown in the figure. At some instant, the electromagnet releases which allows the ball to fall and hit the floor of the cabin. Material of the floor is such that the ball comes to rest in a very short interval of time. For calculation purpose, treat the ball as a point mass.

- (a) For the following 4 graphs (Figures P, Q, R and S), the time interval of collision is too small to fit into the time scale on X-axis.

Which of these four graphs would best represent the time variation of the force felt by the weighing machine while this process takes place?

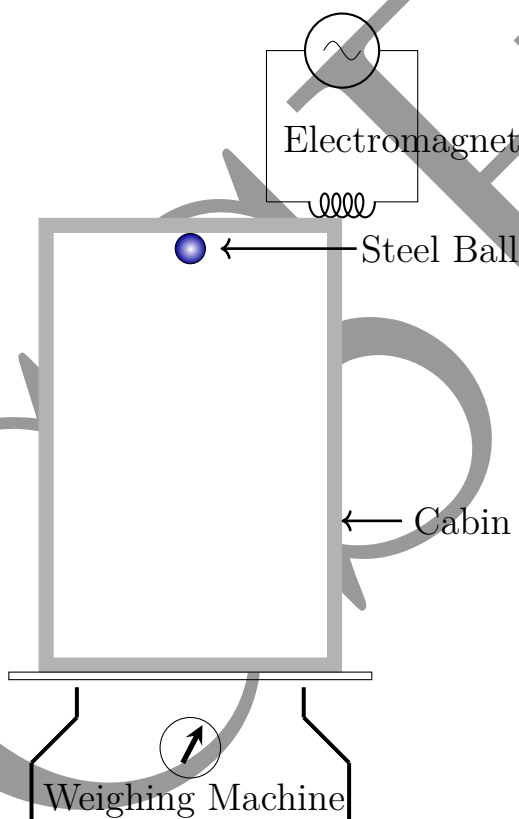

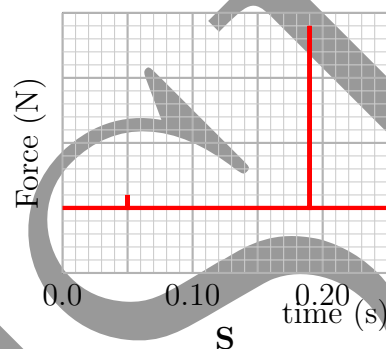
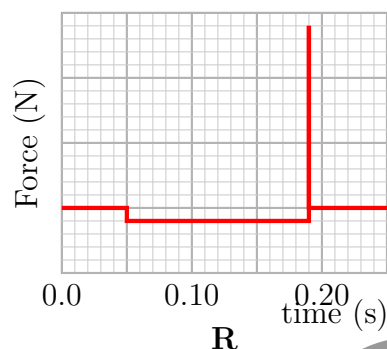
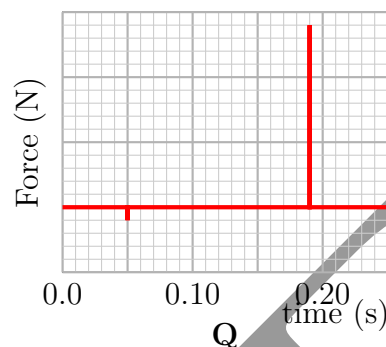
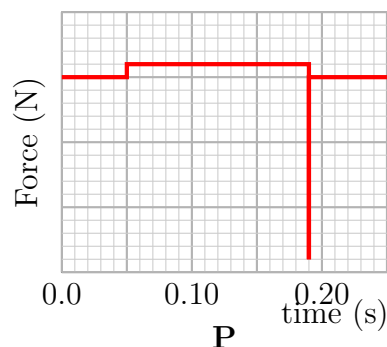

- (b) Determine the height of the cabin using the data from the graph.
- (c) Determine weighing machine reading in kilogram-weight during time of impact assuming that the colliding force is uniform for that time interval.
- (d) Estimate the time interval for collision.

### Solution:

- (a) Option graph (R) is correct. As the ball is released, its weight is no longer reflected in the weighing machine. Hence, the weighing machine shows smaller weight (depression in the graph) till it impacts after some time. Then, during collision, high impulse is imparted.
- (b) From the graph, the time of fall is  $t = 0.14$  s (time for which there is depression).  
 $\therefore$  Height of the cabin = distance of free fall =  $s = \frac{1}{2}gt^2 = 9.8$  cm
- (c) The depression in the graph is due to the fall of  $100$  g =  $0.1$  kg mass, i.e., corresponds to  $0.1$  kg – wt. From the graph R, it can now be seen that the impulsive force is  $1.5$  kg – wt (15 units on graph  $\times$   $0.1$  kg – wt). During impact, the weighing machine detects following weights:
- Weight of cabin  $4.0$  kg – wt
  - Weight of the electromagnet  $0.5$  kg – wt, and
  - impulsive force during the collision  $1.5$  kg – wt. It thus records  $4.0 + 0.5 + 1.5 = 6.0$  kg – wt.

- (d) Downward velocity at the time of impact,  $v = 0 + gt = 1.4 \text{ m/s}$ .  
 Thus, Initial momentum =  $mv = 0.14 \text{ kg m/s}$ . Final momentum is zero.  
 Thus, change in momentum, or momentum transferred during collision  
 $\delta p = 0.14 \text{ kg m/s}$   
 Impulsive force is  $1.5 \text{ kg} - wt = 15 \text{ N}$ .  
 $\therefore \delta p = \text{Impulsive force} \times \text{time interval of collision } \delta t$   
 $\therefore \delta t = \frac{0.14}{15} = 9.3 \times 10^{-3} \text{ s} = 9.3 \text{ ms}$

33. (11 marks) In a laboratory experiment, a student designs an electric circuit in which a battery of emf  $18 \text{ V}$  with negligible internal resistance is connected to a network of three resistors  $R_1$ ,  $R_2$  and  $R_3$  as shown in figure below.  $R_1 = R_2 = 100 \Omega$  and  $R_3 = 300 \Omega$ .

She measures the potential difference across  $R_3$  to be  $14.4 \text{ V}$  with the help of a non-ideal voltmeter. Now she disconnects the voltmeter and connects a non-ideal ammeter in this circuit to measure current flowing through  $R_2$ . This ammeter reads  $20 \text{ mA}$ .

She now connects the same voltmeter and ammeter simultaneously to measure potential difference across  $R_3$  and current flowing through  $R_2$  respectively. Determine the voltmeter and ammeter readings in this case.

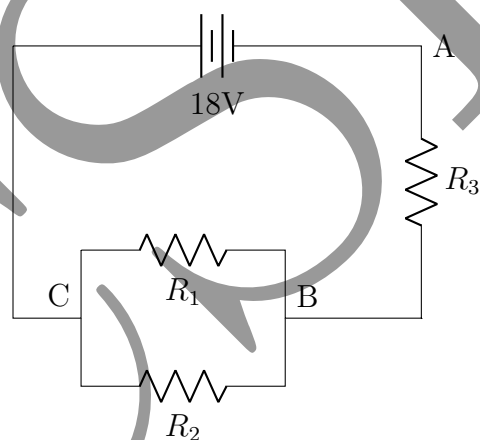

**Solution:**

Case A: Only voltmeter of resistance  $R_V$  connected:

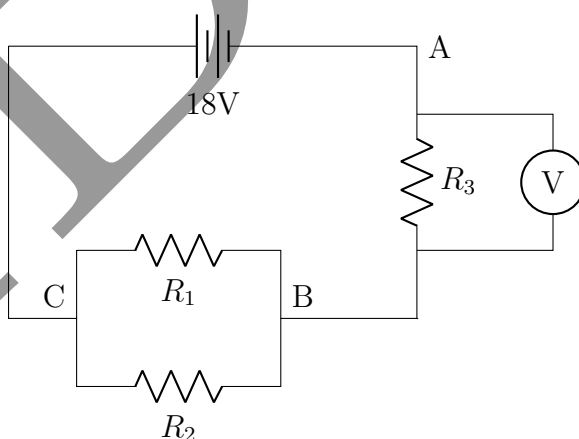

$$\begin{aligned}
 V_{AB} &= 14.4 \text{ V} \\
 \therefore V_{CB} &= 18 - 14.4 = 3.6 \text{ V} \\
 R_{CB} &= 50 \Omega \\
 \therefore I_{CB} &= I_{AB} = \frac{3.6}{50} = 0.072 \text{ A} \\
 \therefore R_{AB} &= \frac{V_{AB}}{I_{AB}} = \frac{14.4}{0.072} = 200 \Omega \\
 \therefore \frac{1}{200} &= \frac{1}{300} + \frac{1}{R_V} \\
 \therefore R_V &= 600 \Omega
 \end{aligned}$$

Case B: Only ammeter of resistance  $R_A$  connected:

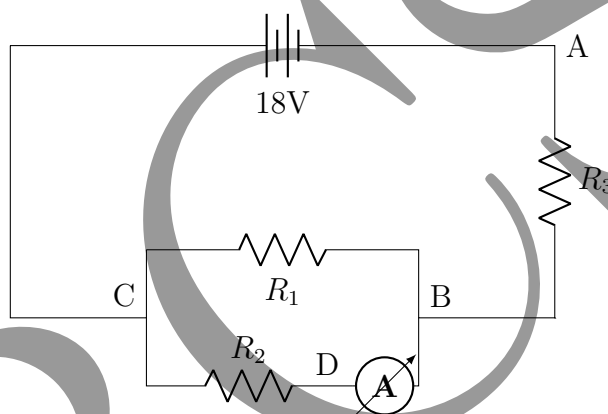

Between points C and B, let  $I$  be the current through the upper  $100 \Omega$  resistor (where ammeter is not there).

Current of  $20 \text{ mA}$  ( $0.02 \text{ A}$ ) is flowing through ammeter of resistance  $R_A$ .

$\therefore$  Voltage across these two parallel branches is  $V_{CB} = (100)I = (100 + R_A)0.02$

$$\therefore I = \left( \frac{1}{50} + \frac{R_A}{5000} \right) \quad (1)$$

Current drawn from the battery, i.e. current through  $R_3 = 300 \Omega$  is  $(0.02 + I)$  Total battery voltage of  $18 \text{ V}$  then divides as given below:

$$18 = (100 + R_A)(0.02) + 300(0.02 + I) \quad (2)$$

Using I from equation 1 we can solve 2 for  $R_A$ .

$$\therefore R_A = 50 \Omega$$

Case C: Both voltmeter of resistance  $600 \Omega$  and ammeter of resistance  $50 \Omega$  are connected.



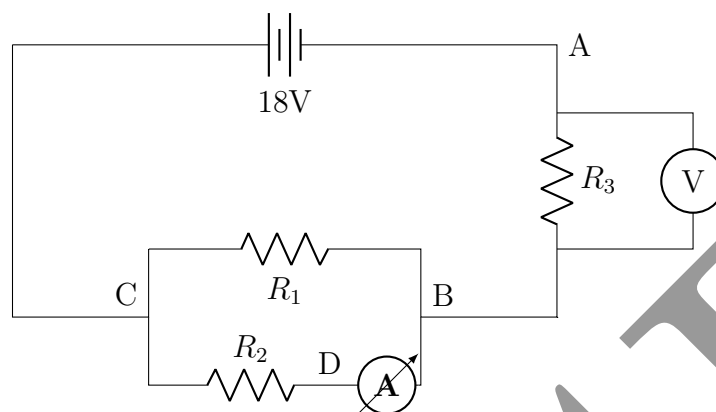

$$R_{CB} = 100 \Omega \text{ and } 150 \Omega \text{ parallel} = 60 \Omega$$

$$R_{AB} = 300 \Omega \text{ and } 600 \Omega \text{ parallel} = 200 \Omega$$

$$\therefore I_{AB} = \frac{18}{260} \text{ A}$$

$$\therefore V_{AB} = \text{voltmeter reading} = 200 \times \frac{18}{260} = 13.8 \text{ V}$$

Between points C and B, the current of  $\frac{18}{260}$  A divides in the ratio 3:2 (upper : lower)

$$\therefore \text{Ammeter reading} = \text{current through CDB} = \frac{18}{260} \times \frac{2}{5} = 0.02769 \text{ A} = 28 \text{ mA}$$

34. (7 marks) A spring balance (P) reads 625 g when a cubical block of edge length 5 cm is suspended in air from it. Another pan balance (Q) reads 5.000 kg when a container filled with a liquid of density  $1.2 \text{ g/cm}^3$  is put on its pan. These two preliminary readings are **not** shown as separate figures.

The spring balance, along with the cubical block suspended, is now arranged in such a way that the cubical block is partially submerged in the liquid inside the container. The height of the cube above the liquid is 3 cm (left panel of the figure). Neglect the upthrust of air.

- Compute the respective readings of balances P and Q as shown in the left panel of the figure.
- Assuming that spring of the spring balance extends linearly with applied force at a rate  $50 \text{ N/m}$ , calculate the maximum additional mass  $m$  that can be put on top of the block, such that only the upper mass remains above the liquid. What will be the respective readings of balance P and Q in this situation (right panel of the figure)?

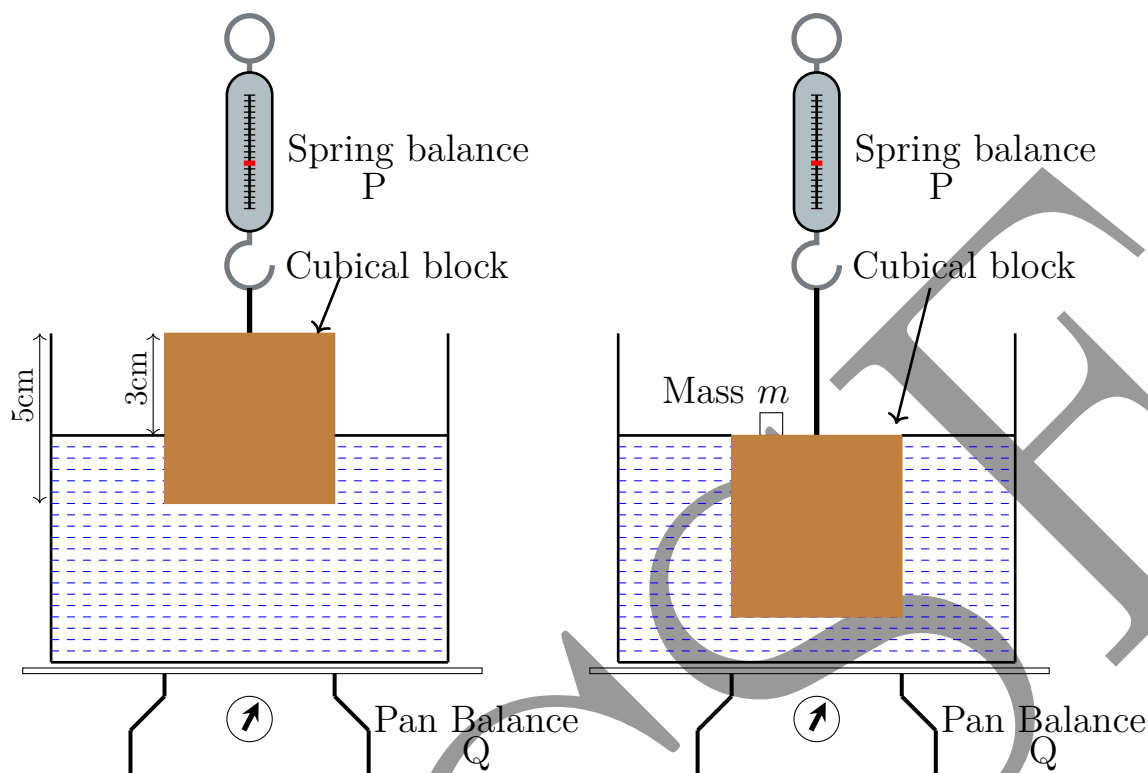

**Solution:**

- (a) In the left figure,  
 upthrust on the block (in gwt) = weight of liquid displaced  
 $= (2 \times 5 \times 5) \text{cm}^3 \times 1.2 \text{g/cm}^3 = 60 \text{gwt}$   
 $\therefore$  Reading of the balance P =  $625 - 60 = 565 \text{g}$   
 Reading of the balance Q =  $5.000 + 0.060 = 5.060 \text{kg}$
- (b) Suppose the maximum mass that can be put on the block, without wetting that mass is  $m$ .  
 Additional forces on the block will now be  
 (i)  $mg$  (downwards) =  $mgwt$   
 (ii) Additional upthrust =  $(3 \times 5 \times 5) \times 1.2 = 90 \text{gwt}$   
 (iii) Additional upward restoring force, as the spring extends by 3 cm is  
 $F = 50 \text{N/m} \times 3 \text{cm} = 50 \text{gwt/cm} \times 3 \text{cm} = 150 \text{gwt}$   
 As the block is still in equilibrium, additional forces must balance  
 $\therefore m = 90 + 150 = 240 \text{gwt}$   
 As compared to situation in the left figure, the upthrust increases by 90 gwt. Thus,  
 the reading of balance P =  $565 + 240 - 90 = 715 \text{gwt}$   
 And the reading of balance Q =  $5.060 + 0.090 = 5.150 \text{gwt}$

35. (5 marks) A gymnast (G) performing in a circus takes a swing with the help of a rod of length  $l$  hinged at point O. He starts the swing with the rod in the horizontal position and leaves

the rod at the lowest position of the swing. There is a protecting net at depth  $h$  below the lowest point of the swing (see figure). Just for the sake of calculations, assume the gymnast to be a particle.

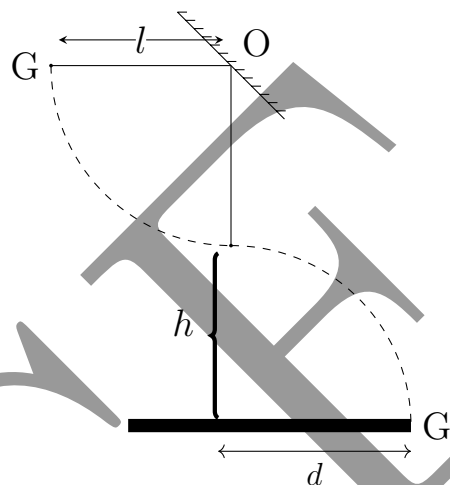
- Determine the horizontal distance  $d$  covered by the gymnast from the point of leaving the rod till he reaches the protecting net.
- Obtain the ratio of  $l$  and  $h$  so that the horizontal distance  $d$  covered by the gymnast from the point of release is maximum.
- The gymnast performs the same feat on an unknown planet almost like earth, except that its gravitational acceleration is half that of the earth. By what factor will  $d$  be affected?



### Solution:

- Horizontal velocity at point B is related as  $\frac{1}{2}mv^2 = mgl \therefore v = \sqrt{2gl}$

Time taken for the vertical displacement  $h$

$$h = \frac{1}{2}gt^2$$

$$\therefore t = \sqrt{\frac{2h}{g}}$$

Horizontal displacement

$$H = \sqrt{2gl} \sqrt{\frac{2h}{g}} = 2\sqrt{(l \cdot h)}$$

- The sum  $(l + h)$  is constant, and we want  $\sqrt{(l \cdot h)}$  to be maximum (for H to be maximum). This will be possible only if  $l = h$ .

Proof : Let  $y = l + h$

$$\therefore \text{Two parts of } y \text{ will be } l = \left(\frac{y}{2} + x\right) \text{ and } h = \left(\frac{y}{2} - x\right) \therefore lh = \left(\left[\frac{y}{2}\right]^2 - x^2\right)$$

Thus, for  $lh$  to be maximum,  $x^2$  should be zero.  $\therefore l = h$ .

- It is seen that  $d$  is independent of value of  $g$ . There will be no change in the horizontal displacement  $H$  from the point of release if the gymnast performs the same on the other planet with acceleration due to gravity is half of the acceleration due to gravity on the surface of the earth.