

SECTION A

Q. No.	(a)	(b)	(c)	(d)	Q. No.	(a)	(b)	(c)	(d)
1	<input type="checkbox"/>	<input type="checkbox"/>	<input checked="" type="checkbox"/>	<input type="checkbox"/>	16	<input type="checkbox"/>	<input type="checkbox"/>	<input type="checkbox"/>	<input checked="" type="checkbox"/>
2	<input type="checkbox"/>	<input type="checkbox"/>	<input type="checkbox"/>	<input checked="" type="checkbox"/>	17	<input type="checkbox"/>	<input checked="" type="checkbox"/>	<input type="checkbox"/>	<input type="checkbox"/>
3	<input checked="" type="checkbox"/>	<input type="checkbox"/>	<input type="checkbox"/>	<input type="checkbox"/>	18	<input type="checkbox"/>	<input checked="" type="checkbox"/>	<input type="checkbox"/>	<input type="checkbox"/>
4	<input type="checkbox"/>	<input type="checkbox"/>	<input checked="" type="checkbox"/>	<input type="checkbox"/>	19	<input type="checkbox"/>	<input checked="" type="checkbox"/>	<input type="checkbox"/>	<input type="checkbox"/>
5	<input type="checkbox"/>	<input type="checkbox"/>	<input type="checkbox"/>	<input checked="" type="checkbox"/>	20	<input checked="" type="checkbox"/>	<input type="checkbox"/>	<input type="checkbox"/>	<input type="checkbox"/>
6	<input checked="" type="checkbox"/>	<input type="checkbox"/>	<input type="checkbox"/>	<input type="checkbox"/>	21	<input checked="" type="checkbox"/>	<input type="checkbox"/>	<input type="checkbox"/>	<input type="checkbox"/>
7	<input type="checkbox"/>	<input type="checkbox"/>	<input checked="" type="checkbox"/>	<input type="checkbox"/>	22	<input type="checkbox"/>	<input type="checkbox"/>	<input checked="" type="checkbox"/>	<input type="checkbox"/>
8	<input type="checkbox"/>	<input checked="" type="checkbox"/>	<input type="checkbox"/>	<input type="checkbox"/>	23	<input type="checkbox"/>	<input checked="" type="checkbox"/>	<input type="checkbox"/>	<input type="checkbox"/>
9	<input type="checkbox"/>	<input type="checkbox"/>	<input checked="" type="checkbox"/>	<input type="checkbox"/>	24	<input type="checkbox"/>	<input type="checkbox"/>	<input type="checkbox"/>	<input checked="" type="checkbox"/>
10	<input type="checkbox"/>	<input checked="" type="checkbox"/>	<input type="checkbox"/>	<input type="checkbox"/>	25	<input type="checkbox"/>	<input checked="" type="checkbox"/>	<input type="checkbox"/>	<input type="checkbox"/>
11	<input type="checkbox"/>	<input type="checkbox"/>	<input checked="" type="checkbox"/>	<input type="checkbox"/>	26	<input checked="" type="checkbox"/>	<input type="checkbox"/>	<input type="checkbox"/>	<input type="checkbox"/>
12	<input type="checkbox"/>	<input type="checkbox"/>	<input checked="" type="checkbox"/>	<input type="checkbox"/>	27	<input checked="" type="checkbox"/>	<input type="checkbox"/>	<input type="checkbox"/>	<input type="checkbox"/>
13	<input type="checkbox"/>	<input type="checkbox"/>	<input type="checkbox"/>	<input checked="" type="checkbox"/>	28	<input type="checkbox"/>	<input type="checkbox"/>	<input type="checkbox"/>	<input checked="" type="checkbox"/>
14	<input type="checkbox"/>	<input type="checkbox"/>	<input checked="" type="checkbox"/>	<input type="checkbox"/>	29	<input type="checkbox"/>	<input type="checkbox"/>	<input checked="" type="checkbox"/>	<input type="checkbox"/>
15	<input type="checkbox"/>	<input type="checkbox"/>	<input checked="" type="checkbox"/>	<input type="checkbox"/>	30	<input checked="" type="checkbox"/>	<input type="checkbox"/>	<input type="checkbox"/>	<input type="checkbox"/>

SECTION B**Question 31****A)**

PD of 1 V, gains 2 eV therefore charge of ion is -2 C

The number of electrons in the ion = X

Then the number of neutrons will be $X + 25 X/100 = 1.25X$

The number of electrons in the neutral atom = X-2

The number of protons in the neutral atom = X-2

Mass number = No. of Protons + No. of neutrons

$$79 = X-2 + 1.25X$$

$$2.25 X = 81$$

$$X = 81 / 2.25 = 36$$

Number of protons = $36 - 2 = 34$ Hence the element is Se Symbol of Ion is Se^{-2}

B)

A = Ca B = $CaOCl_2$ Y = $Ca(OH)_2$ Z = $CaSO_4$

Reactions: $2Ca + O_2 \rightarrow 2CaO$

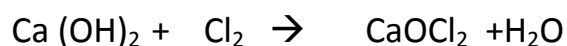
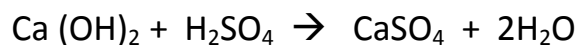

OR $2Ca(OH)_2 + 2Cl_2 \rightarrow Ca(ClO)_2 + CaCl_2 + 2H_2O$

Question 32

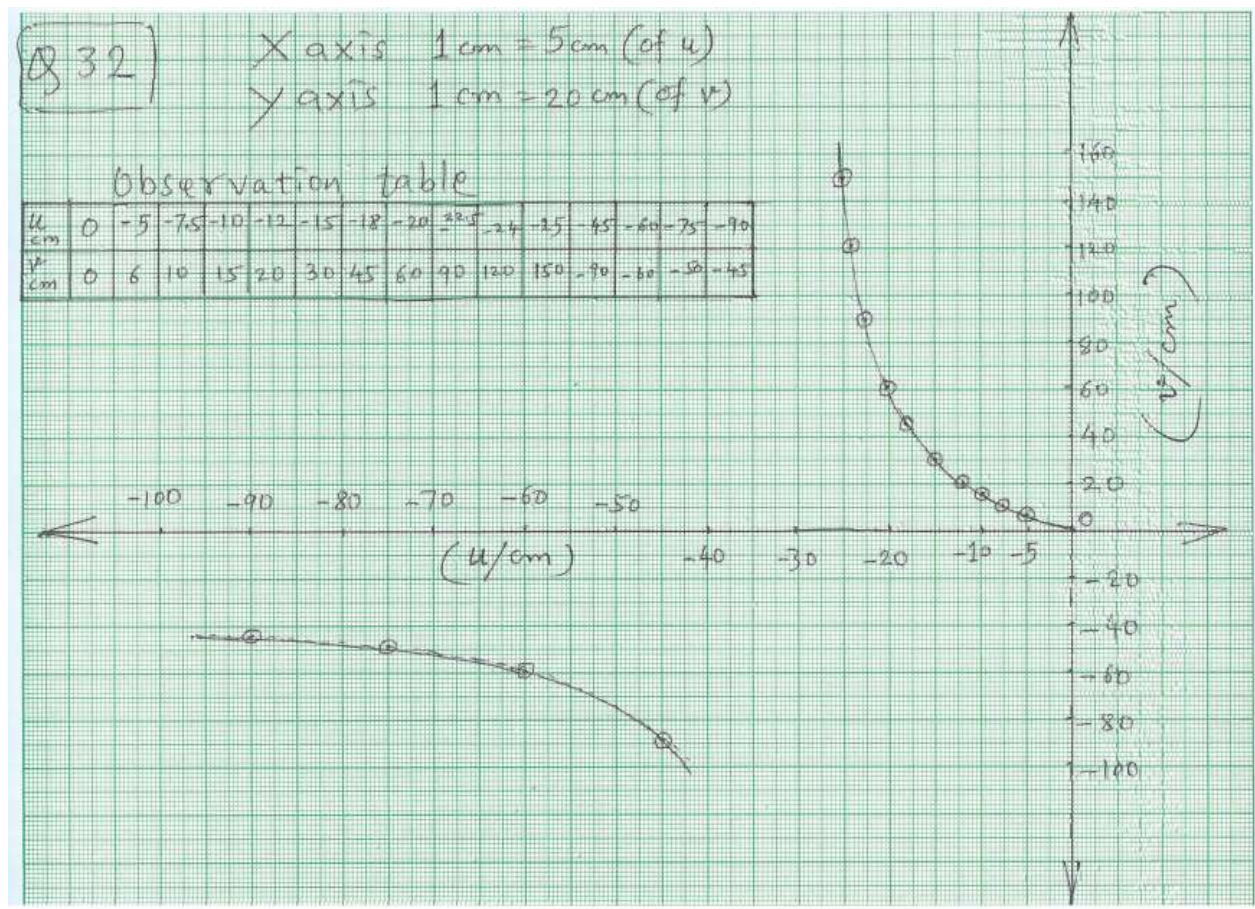

Question 33

- I. Weight of glucose given = 10 g
- 180 g glucose refers to 1 mole
- 10g of glucose will be: $10/180 = 0.0555$ moles

- II. 1 molecule of glucose forms 2 molecules of pyruvic acid
- All the glucose thus will produce $0.0555 \times 2 = 0.111$ moles of pyruvic acid

III. One molecule of pyruvic acid forms 1 molecule of lactic acid

Hence all lactic produced from the 25% of the pyruvic acid will be: $0.111/4 = 0.02775$ moles

IV. 1 molecule of pyruvic acid gives 3 molecules of CO₂

Hence moles of CO₂ produced from this pyruvic acid will be: $0.111 \times 3 = 0.333$ moles

V. i) cytoplasm, ii) cytoplasm, iii) mitochondria

Question 34

i)

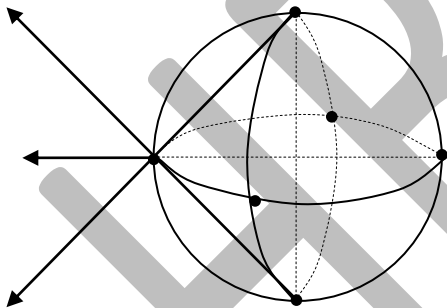

ii) $F_e = \frac{1}{4\pi\epsilon_0} q^2 \left(4 \times \frac{1}{\sqrt{2}} \times \frac{1}{2r^2} + \frac{1}{(2r)^2} \right) = \frac{1}{4\pi\epsilon_0} \left(\sqrt{2} + \frac{1}{4} \right) \left(\frac{e^2}{r^2} \right)$ r = radius of carbon atom

iii) $F_e = (9 \times 10^9) \times (1.66) \times \frac{(1.6 \times 10^{-19})^2}{(2.7 \times 10^{-15})^2} = 52 \text{ N}$

$$\text{iv) } F_g = 6.7 \times 10^{-11} \times 1.66 \times \frac{(1.7 \times 10^{-27})^2}{(2.7 \times 10^{-15})^2} = 4.4 \times 10^{-35} \text{ N}$$

$$\text{v) } \frac{F_e}{F_g} = \frac{52}{4.4 \times 10^{-35}} \approx 1.2 \times 10^{36}$$

vi) Along the diameter, radially outwards.

Question 35

A)

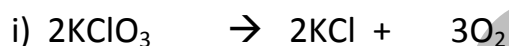

$$2(39 + 35.5 + 48) = 245\text{g}$$

$$3 \times 32 = 96\text{g}$$

Amt. of pure KClO_3 in 90g of 60% purity $(90 \times 0.6) = 54\text{g}$

According to eq(i) 245g of $\text{KClO}_3 = 96\text{g}$ of O_2

$$\therefore 54\text{g of } \text{KClO}_3 = (96 \times 54) / 245 = 21.2\text{g of } \text{O}_2$$

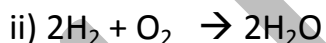

$$4\text{g} \quad 32\text{g}$$

According to eq (ii) 32 g of $\text{O}_2 = 4\text{g}$ of H_2

$$21.2 \text{ g of } \text{O}_2 = (21.2 \times 4) / 32 = 2.65 \cong 2.7 \text{ g of } \text{H}_2$$

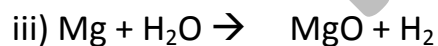

$$24\text{g}$$

$$2\text{g}$$

According to eq (iii) 2 g of $\text{H}_2 = 24\text{g}$ of Mg

$$2.7 \text{ g of } \text{H}_2 = (24 \times 2.7) / 2 = 32.4 \text{ g of } \text{Mg}$$

$$\text{OR } 2.65 \text{ g of } \text{H}_2 = (24 \times 2.65) / 2 = 31.8 \text{ g of } \text{Mg}$$

B)

This is a thermite reaction.

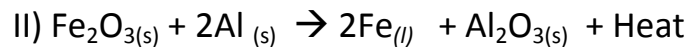
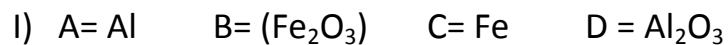

Displacement reaction

III) Amphoteric

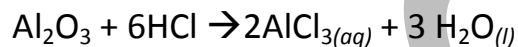
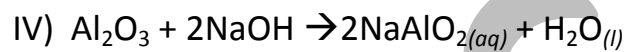

Question 36

I) i) Autosomal recessive: **a. and b.**

ii) X-linked recessive: **a. and b.**

II) Option **d** is correct. **2/3**

III)

i. Son answer: **0**

ii. Daughter answer : **1**

Question 37

i) Since the tank is moving with uniform velocity, the free surface of water will remain horizontal (No need to sketch the free surface)

ii) After $t = 5$ s, since the tank is accelerated uniformly, the free surface will not remain horizontal. In fact a pseudo force (or pseudo acceleration) will act in the tank frame in the opposite direction. This makes the free surface inclined to the horizontal with water rising along the backside. The situation will be as shown.

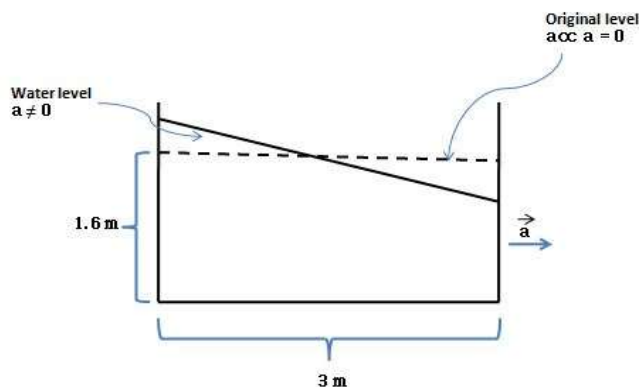

iii) To find the maximum acceleration a_{\max} for the water not to spill over, the situation is as shown below.

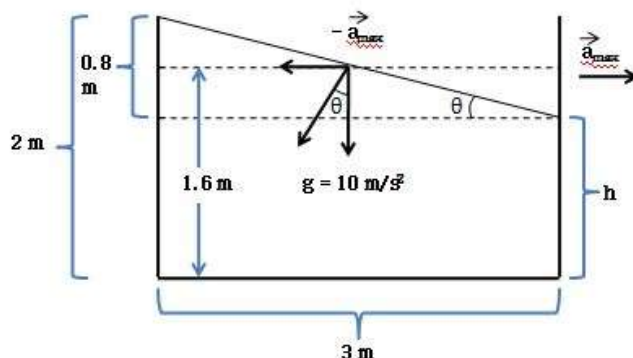

To find h , we equate the volumes in the two situations with changed geometry.

The surface tilts uniformly and it is plane even in the tilted position (as shown in the figure).

The free surface of water will remain perpendicular to the net acceleration which is the vector sum of g (downwards) and $-a_{max}$ (pseudo acceleration) as shown.

From simple geometry,

$$\tan \theta = \frac{0.8}{3} = \frac{a_{max}}{10}$$

$$\therefore a_{max} = \frac{10 \times 0.8}{3} = \frac{8}{3} = 2.66 \text{ m/s}^2$$

iv) The correct option is (d). The air bubble always travels perpendicular to the free surface.

Question 38

A)

Molecular mass of ammonium chloride (NH_4Cl) = $14+4+35.5= 53.7$

10.7 % of ammonium chloride = 2 molar ammonium chloride solution



74g

34 g

Ammonia gas produced in the above reactions now reacts with 23.85 g CuO

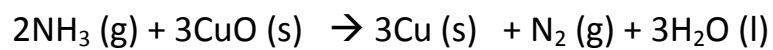

2 mole 3 moles 3 moles

2 x 17 3 x 79.5 3 x 63.5

34 238.5g 190.5g

3.4 23.85g 19.05g

Amount of slaked lime required is 7.4 g

Amount of Copper obtained is 19.05 g

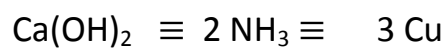

74 34 190.5

B)

i) O_3 OR AsCl_3

ii) g OR Mn (+2 to +7)

iii) g OR KMnO_4

iv) Coinage elements: h, j, k OR Fe, Ni, Cu

v) o OR As

vi) l OR Zn

Question 39

1. The correct option is (b) i.e Keep the plant in dark for about 48 hours before starting the experiment.
2. The correct option is (c) i.e Iodine solution
3. The correct option is (c) i.e Excitation of chlorophyll
4. The correct option is (a) i.e Accumulation of more water
5. The correct option is (c) i.e Sucrose
6. The correct option is (b) i.e As long as the test tube is illuminated by white light and sodium bicarbonate is present in it.

Question 40**A)**

$$qV = \text{Change in kinetic energy} = \frac{1}{2}m(v^2 - u^2)$$

$$q \cdot 10 = (1/2)(0.02)(40^2 - 20^2) = 12$$

$$q = 1.2 \text{ C}$$

B)

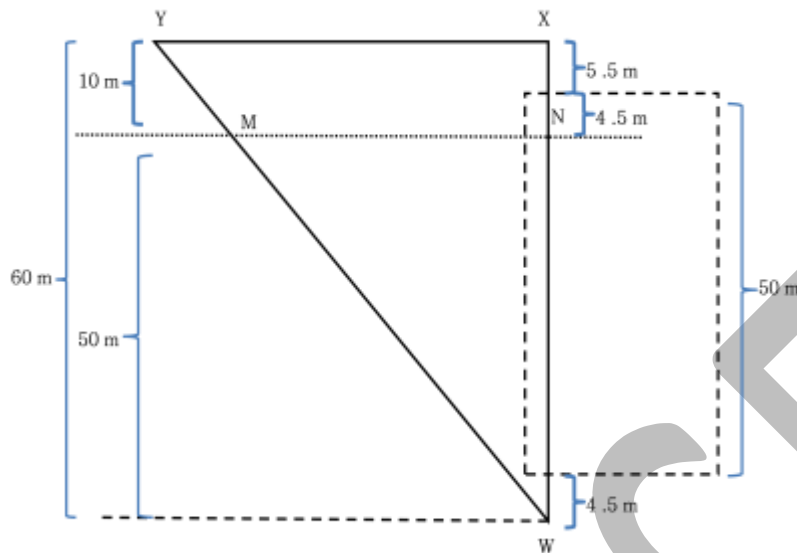

i) Mass of ice = $V/910 \text{ kg} = A \times 50 \times 910 \text{ kg}$

So mass of water displaced = $A \times h \times 1000 \text{ kg}$.

$$50 \times 910 = h \times 1000$$

$$h = 50 \times .91 = 45.5 \text{ m}$$

So 4.5 m of ice projects out of water (is above the surface of water). Hence there is 5.5 m of air between X and ice surface.

Also whale is 4.5 m below the sheet of ice.

$$\text{ii) } YW = (6400 + 3600)^{1/2} = 100 \text{ m}$$

Taking ratio of 10/60 in 100m gives $YM = 16.6 \text{ m}$ and $MW = 83.4 \text{ m}$.

iii) Time taken *for the sound* to reach Y is $(16.6/350 + 83.4/1500) = 0.103 \text{ s}$ iv)

Time taken to travel to x = 0.033 s

v) Travel time in air is $5.5/350 = 0.016 \text{ s}$ and in water below the sheet of ice it is $4.5/1500 = 0.003 \text{ s}$ with total time 0.019 sec. Travel time of sound in ice is thus $0.033 - 0.019 = 0.014 \text{ s}$ for 50 m hence its speed in ice is 3571 m/s.

Question 41**A)**

Vol of 2 drops of 1 M NaOH = $(6 \times 2) / 100 = 0.12$ mL

Conc of HCl = $(\text{conc NaOH} \times \text{vol NaOH}) / \text{vol HCl} = (0.12 / 5) = 0.024$ M

Grams of HCl = $(0.024 \times 5 \times 36.5) / 1000 = 0.00438$ g

B)

(i) Molarity of sodium hydroxide,
 $M = 0.05 \times 10 \times 2 / 11.3 = 0.0885$ M

Amount of NaOH in the solution
gm/ 250 mL. of NaOH,
 $= 40 \times 0.0885 \times 250 / 1000 = 0.885$ g

Amount of NaOH spilled = $1 - 0.885 = 0.115$ g

(ii) 1000mL 1Molar any solution contain 6.02×10^{23} molecules

Number of NaOH molecules in 0.0885 M 11.3 mL

$$= (0.0885 \times 11.3 \times 6.02 \times 10^{23}) \div 10^3$$

$$= 6.02 \times 10^{20} \text{ molecules of NaOH}$$

Number of dibasic acid molecules in 0.05 M 10 mL

$$= (0.05 \times 10 \times 6.02 \times 10^{23}) \div 10^3$$

$$= 3.01 \times 10^{20} \text{ molecules of dibasic acid}$$

Question 42

A) I) 5.

II) A= 400J, B= 400J, C=400J, D=20J, E=84J, F=20J

III) Grass -> Rabbit -> Eagle

B) I) The correct option is (a) i.e 12 J

II) The correct option is (c) i.e 75 %

C) The correct option is (a) i.e (a) Birds → Mammals → Fishes → Microorganisms.