

Questions (INJSO 2014)

Section A: Questions 1 to 60 are multiple choice with every correct answer carrying 1 mark and every wrong answer carrying -0.25 mark.

SECTION A

- Q1.** If an axolotl larva of Mexican *Salamander* is kept in iodine depleted water; then
- It will fail to metamorphose but become sexually mature
 - There will be no effect on its metamorphosis
 - It will metamorphose but remain sexually immature
 - It will fail to metamorphose and will remain sexually immature
- Q2.** Which of the following is an oxidation – reduction reaction?
- $\text{H}_3\text{O}^+ (\text{aq}) + \text{CO}_3^{2-} (\text{aq}) \rightarrow \text{HCO}_3^- (\text{aq}) + \text{H}_2\text{O}$
 - $\text{HNO}_3 (\text{aq}) + \text{NH}_3 (\text{aq}) \rightarrow \text{NH}_4^+ (\text{aq}) + \text{NO}_3^- (\text{aq})$
 - $\text{Mg} (\text{s}) + \text{F}_2 (\text{g}) \rightarrow \text{MgF}_2 (\text{s})$
 - $\text{Pb}(\text{NO}_3)_2 (\text{aq}) + 2 \text{NaCl} (\text{aq}) \rightarrow \text{PbCl}_2 (\text{s}) + 2\text{NaNO}_3 (\text{aq})$
- Q3.** Which of the following cannot be visible from our moon?
- Annular eclipse of the Sun.
 - Partial eclipse of the Earth.
 - Total eclipse of the Sun.
- I and II
 - II and III
 - I and IV
 - Only II
- Q4.** The immature male germ cells undergo division to produce sperms by the process of spermatogenesis. Which of the following sentences is correct regarding this process?
- The primordial germ cells always undergo meiotic division.
 - The primordial germ cells divide only by mitotic division.
 - Secondary spermatocytes undergo second meiotic division only.
 - Spermatozoa are formed from spermatids by meiotic division.

Q5. Which of the following will change the value of the equilibrium constant for the reaction?

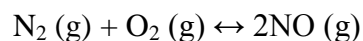

- a) Add more N_2 b) Increase of pressure
c) Use a smaller reaction vessel d) Increase the temperature
- Q6.** Particles P and Q are undergoing uniform horizontal circular motions along concentric circles of different radii in clockwise sense. P completes each round in 2 minutes while Q does it in 5 minutes. Time required by Q to make one revolution around P is
- a) 3 minutes b) 10 minutes
c) $10/3$ minutes d) This is not possible as Q is moving slower than P.
- Q7.** Which type of reproduction, from the following, gives evidence that the genetic information needed for the complete development of an individual is contained actually in a haploid set of chromosomes?
- a) Budding in hydra
b) Multiple fission in amoeba
c) Development of male honey bee (Drone) from egg
d) Binary fission in paramecium
- Q8.** The amount of CaCO_3 which will precipitate if 50ml of 1.0M Na_2CO_3 and 50ml of 0.2M CaCl_2 are mixed is
- a) 5.0 g b) 2.0 g
c) 1.0 g d) 0.5 g
- Q9.** Which of the following statements regarding pollen grain is correct?
- a) Tapetum nourishes the developing pollen.
b) Sporogenous tissue in the anther is haploid
c) Endothesium produces the microspores.
d) Only pollen cannot produce a complete plant in any condition.
- Q10.** Help Sachin to calculate the osmotic pressure of 0.9% aqueous solution of solute X at 25°C . Molar mass of the solute is 60g/mol. ($R = 0.0820 \text{ lit-atm K}^{-1} \text{ mol}^{-1}$)
- a) 3.66×10^{-3} atm b) 3.66 atm.
c) 2.44 atm d) 1.63×10^{-3} atm

Q11. Which of the following observations recorded are having FOUR and only FOUR significant figures?

- i) 134.400 m
 - ii) 7680 g
 - iii) 0.0849 N
 - iv) 2.000 J
- a) (i), (iii) and (iv) b) Only (ii)
c) Only (iv) d) (ii) and (iv) only

Q12. A truck and a car moving with the same kinetic energy are brought to rest by application of brakes which provide equal total retarding force for both. The truck has 8 tyres, and weighs 4 times more than the car which has 4 tyres. What can you say about the distance in which the two vehicles stop?

- a) The car will stop at a shorter distance.
- b) The truck will stop at a shorter distance.
- c) They will stop at the same distance.
- d) Not enough information is given.

Q13. Which of the following can be categorized as a parasite in true sense?

- a) The female Anopheles mosquito sucks blood from human
- b) Human foetus developing in uterus draws nourishment from mother
- c) Head louse lives on human scalp and lays eggs on hair.
- d) The cuckoo lays eggs in crow's nest for subsequent parental care.

Q14. A human T lymphocyte in the mitotic metaphase stage will contain how many DNA molecules? (Exclude the DNA of mitochondria)

- (a) 23 (b) 46
- (c) 184 (d) 92

Q15. In an mRNA the codons are read linearly and each codon consists of three consecutive nucleotides which codes for one amino acid. During a deletion mutation, a deletion of three consecutive bases in the coding region of a gene **cannot** result in one of the following.

- a) Deletion of a single amino acid without any other change in the protein.
- b) Replacement of two adjacent amino acids by a single amino acid.
- c) Replacement of a single amino acid by another without any other change in sequence of the protein.
- d) Production of a truncated (shorter) protein.

- Q16.** Find the number of quanta of radiations of frequency $7.55 \times 10^{15} \text{ s}^{-1}$ that must be absorbed in order to melt 6 g of ice. The approximate energy required to melt 1g of ice is 333 J. ($h=6.62 \times 10^{-34} \text{ Js}$)
- a) 0.90×10^{22} b) 0.111×10^{20}
c) 5.38×10^{22} d) 3.99×10^{20}
- Q17.** In a certain system of units, force (F), velocity (v) and time (T) are fundamental quantities and (K) is used for temperature. Dimensions of specific latent heat in this system are
- a) $[v^2]$ b) $[F v T / K]$
c) $[F v T]$ d) None of the above
- Q18.** For several days, the temperature at the bottom of a pond is 4°C and the air temperature just above the top surface of the pond is -1°C . Depth of the pond is L. The Thermal conductivity of ice is 3 times that of water. Thickness of frozen layer of the ice formed must be
- a) $3L/4$ b) $4L/5$
c) $3L/5$ d) $3L/7$
- Q19.** How much energy in kJ is produced when 7.1 g of gaseous chlorine atoms are converted to gaseous chloride ions?
(Electron affinity of chlorine is -3.7 eV . ($1 \text{ eV/atm} = 96.49 \text{ kJ/moles}$))
- a) 35.7 kJ b) 26.2 kJ
c) 68.5 kJ d) 71.4 kJ
- Q20.** A satellite is launched in a circular orbit of radius R. Another satellite is also launched in an orbit of radius 1.1R. The period of the second satellite is larger than the first by approximately.....
- a) 7.5% b) 1.5%
c) 15% d) 10%
- Q21.** Amol took 10 mL .of $2.2 \times 10^{-5} \text{ M}$ hydrochloric acid solution. He then diluted it to 1 litre. He found that the pH of diluted solution is
- a) 4.7 b) 6.7
c) 4.5 d) 6.5

Q22. The actual path followed by a glucose molecule in the process of aerobic respiration for production of 36 or 38 ATP would be

- a) Cytoplasm ----- mitochondrial matrix ----- oxysomes
- b) Cytoplasm ----- cytoplasm ----- F1 particles
- c) Mitochondrial matrix ----- F1 particles ----- oxysomes
- d) Mitochondrial matrix ----- oxysomes ----- cytoplasm

Q23. There are 3 containers X, Y and Z. X contains 10ml of water and Z contains 10 ml of milk. Y contains 5ml of milk (same as in container Z) mixed with 5 ml of water. All 3 containers have pH value of 6.5. P amount of Acetic acid is added to container X, Q amount to Y and R amount to Z. Such that the final pH value in each container is 5.5. Then which of the following is true.

- a) $P < Q < R$
- b) $P < R = Q$
- c) $P = Q = R$
- d) $P < R < Q$

Q24. During fertilization in amphibians, the fusion of egg and sperm plasma is preceded by

- (P) Release of enzymatic contents from the acrosomal vesicle through exocytosis.
- (Q) Binding and interaction of the sperm to vitelline membrane.
- (R) Chemo-attraction of the sperm to the egg by soluble factors secreted by egg.
- (S) Release of the sperm nucleus into the ooplasm.

Which of the following is the correct sequence?

- a) P-Q-S-R
- b) Q-P-R-S
- c) R-P-Q-S
- d) R-Q-P-S

Q25. A short length linear DNA molecule has 110 thymine and 110 guanine bases. The total number of nucleotide in the DNA fragment will be

- a) 110
- b) 880
- c) 440
- d) 220

Q26. Which of the following solution will form a precipitate with excess 0.1M KOH but not with excess 0.1M NH_3 ?

- a) AgNO_3
- b) AlCl_3
- c) BaCl_2
- d) MgCl_2

Q27. Three different circuits (I, II and III) are constructed using identical batteries and resistors of R and $2R$ ohm. What can be said about current I in arm AB of each circuit?

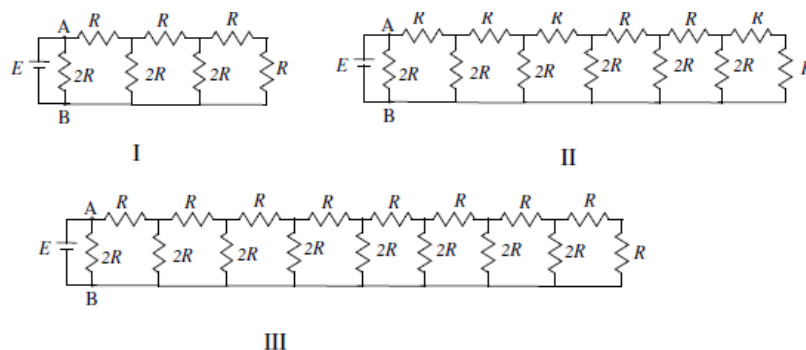

- a) $I_I > I_{II} > I_{III}$ b) $I_I < I_{II} < I_{III}$
 c) $I_{II} < I_I < I_{III}$ d) $I_I = I_{II} = I_{III}$

Q28. On a summer day one feels very uncomfortable sitting in a room, without an air conditioner. A bucket of water is kept in the middle of the room for a long time. Room is thermally insulated from the outside environment.

Which of the following statement is /are correct?

- i) If one puts her / his hand in the water, she / he feels water in the bucket to be cooler because the water is at a lower temperature than the surrounding.
- ii) The quantity of water in the bucket will not change with time.
- iii) If ice is brought into the room, the ice begins to melt and the room temperature begins to fall. The room temperature and the temperature of the water in the bucket will fall jointly.
- iv) Two persons enter the room. Person M is medically normal but person N has fever with body temperature 104°F . M claims that water kept in a bucket is warm but N claims that water is cool. Then the water temperature can be 39°C . [Hint : Boiling point of water at normal pressure is $100^\circ\text{C} = 212^\circ\text{F}$. Freezing point of water at normal pressure is $0^\circ\text{C} = 32^\circ\text{F}$].

- a) ii, iii, and iv b) iii and iv
 c) ii, iii d) only iii

- Q29.** An optical system whose cross-section is shown below is constructed from two different glass isosceles wedges (each with a 30° - 75° - 75° cross section). The refractive indices of the two glasses are $\mu_1 = \sqrt{3}$ and $\mu_2 = \sqrt{2}$ respectively. A light beam is incident at an angle of 60° on face AB. The angle of emergence from the face CD is

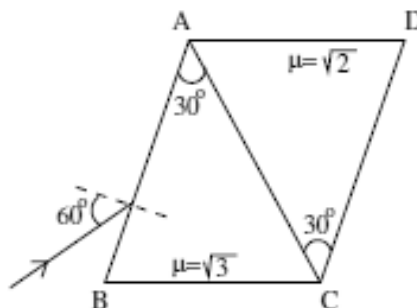

- a) 0°
 b) 45°
 c) 15°
 d) 30°
- Q30.** The given diagram represents a dividing cell stained with giemsa. From the options given below, identify the correct stage of cell division.

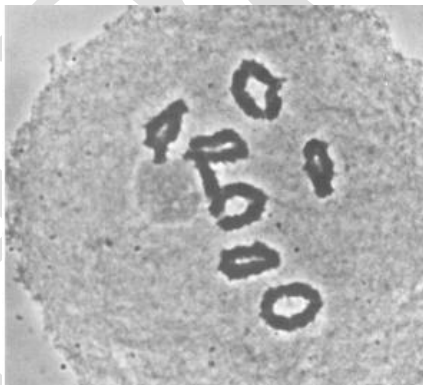

- a) Leptotene
 b) Zygotene
 c) Pachytene
 d) Diakinesis
- Q31.** The electrolysis of aqueous NaOH solution yields
- a) Na at cathode, O_2 at anode
 b) H_2 at cathode, O_2 at anode
 c) H_2 at anode, O_2 at cathode
 d) H_2 at anode, Na at cathode

Q32. A white crystalline salt P reacts with dilute HCl to liberate a suffocating gas Q and also forms a yellow precipitate. The gas Q turns potassium dichromate acidified with H_2SO_4 to a green colored solution R. P, Q and R are?

- a) P: $\text{Na}_2\text{S}_2\text{O}_3$, Q: SO_2 , R: $\text{Cr}_2(\text{SO}_4)_3$
- b) P: Na_2SO_3 , Q: Cl_2 , R: $\text{Cr}(\text{SO}_4)_3$
- c) P: Na_2SO_4 , Q: SO_3 , R: $\text{Cr}_2(\text{SO}_4)_3$
- d) P: Na_2S , Q: Cl_2 , R: $\text{Cr}_2(\text{SO}_4)_3$

Q33. Of the four figures given below, x_0 is known value of the outcome in an experiment. Which of the following data plot a precise but not an accurate measurement?

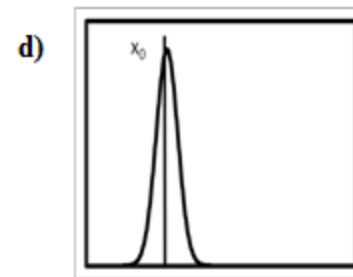
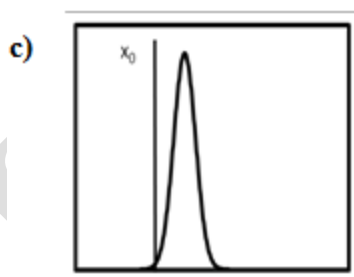
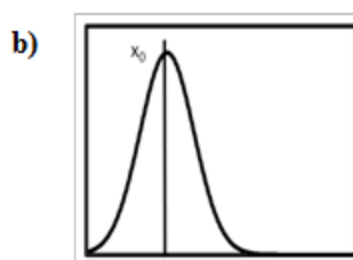
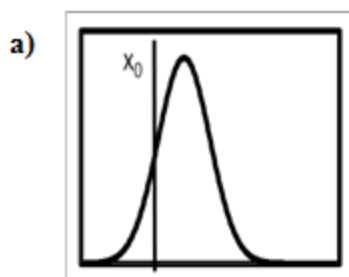

Q34. Stem cells in animals are pluripotent cells as they possess the potential of giving rise to many types of cell lineage. Presence of stem cell in a differentiated tissue gives it potential to regenerate. From the combination of tissues presented below, predict the best combination of tissues containing maximum and minimum amount of stem cells respectively.

- a) Brain and kidney
- b) Kidney and brain
- c) Brain and liver
- d) Liver and brain

- Q35.** For a normal unaided eye the least converging power of the eye lens behind the cornea is 20D and the cornea itself has some converging power. The distance between the retina and the cornea-eye lens can be approximated to $5/3$ cm. Converging power of the cornea is give by:
- a) 2.5D b) 40D
c) 60D d) 19.4D
- Q36.** Given below are few forces of evolution. Which of the following would be the best combination of primary forces of evolution?
- a) Variation and mutation b) Mutation and isolation
c) Variation and migration d) Migration and random genetic drift
- Q37.** How many molecules of water of hydration are present in 252mg of oxalic acid ($H_2C_2O_4 \cdot 2H_2O$)?
- a) 2.68×10^{18} b) 2.52×10^{21}
c) 1.83×10^{24} d) 2.4×10^{21}
- Q38.** Which of the process increases in the absence of light in plants?
- a) Rate of uptake of minerals b) Rate of uptake of water
c) Rate of ascent of sap. d) Elongation of internodes
- Q39.** In the following circuit the ammeter is ideal and reads zero. Value of resistance R is

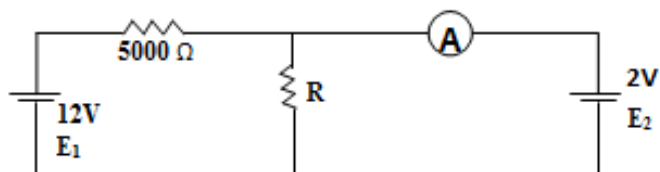

- a) 500Ω b) 1000Ω
c) 25000Ω d) 0.5Ω

Q40. Few statements related to genetic drift are given below. Find out the **incorrect statement** among the four.

- a) There is a random change in the allele frequency in a given population.
- b) It is significant only in large population.
- c) It is a mechanism for evolution of new species.
- d) It may or may not help a species to adapt.

Q41. For the reaction

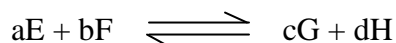

The expression of equilibrium constant can be written as

$$K_c = \frac{[G]^c [H]^d}{[E]^a [F]^b}$$

Where all the concentrations are equilibrium concentrations. Before approaching equilibrium, the same concentration ratio is called reaction quotient Q_c .

For the reaction system to reach equilibrium

- a) Q_c must increase in the reaction
- b) Q_c must decrease in the reaction
- c) $Q_c = K_c$
- d) $Q_c = \text{zero}$

Q42. Child drinks a liquid of density ρ through a vertical straw. Atmospheric pressure is P_0 and the child is capable of lowering the pressure at the top of the straw by 10%. The acceleration of the free fall is g . What is the maximum length of straw that would enable the child to drink the liquid?

- a) $P_0/10 \rho g$
- b) $9P_0/10 \rho g$
- c) $P_0/\rho g$
- d) $10P_0/\rho g$

Q43. In Haber's process 0.240 mole of Nitrogen, 3.9 moles of hydrogen are taken which lead to the formation of 7.8 moles product in a 3.00 litres of reaction vessel at 375°C . Considering that equilibrium constant at this temperature is 41.2 Calculate the value of reaction quotient (Q) and predict whether the reaction is in equilibrium or it will proceed in either direction.

- a) $Q = 38.62$ and reaction will be in equilibrium.
- b) $Q = 19.31$ and reaction will proceed in forward direction.
- c) $Q = 38.62$ and reaction will proceed in forward direction.
- d) $Q = 19.31$ and reaction will proceed in backward direction.

Q44. Variation of the concentration of the reactant (X) and the product (Y) are shown in the figure. Select the correct statement.

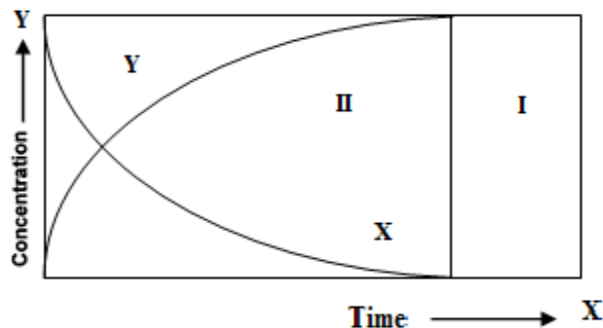

- a) I and II both are kinetic regions.
- b) I and II both are equilibrium regions.
- c) I is equilibrium and II is kinetic region.
- d) I is kinetic and II is equilibrium region.

Q45. A ball falls from rest through air and eventually reaches a constant velocity. For this fall, force X and Y vary with time as shown.

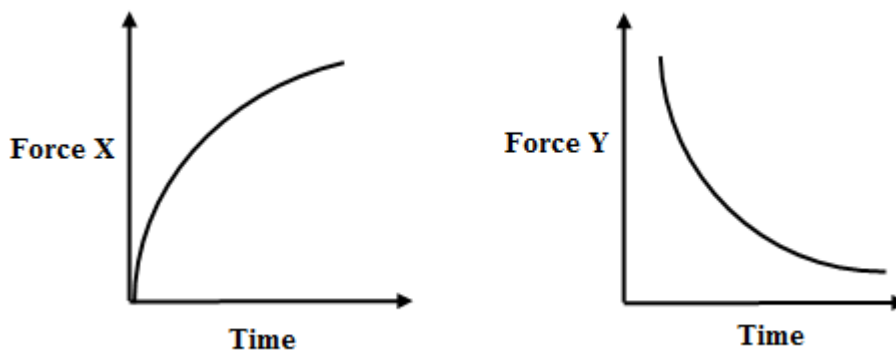

Which of the following should be force X and Force Y?

- | | Force X | Force Y |
|----|----------------|-----------------|
| a) | Air Resistance | Resultant Force |
| b) | Air Resistance | Weight |
| c) | Up thrust | Resultant Force |
| d) | Up thrust | Weight |

Q49. Out of the two X chromosomes of human female, one X chromosome is inactivated and heterochromatinized. The inactive X-chromosome can be seen as a darkly stained spot and is called as Barr body. Identify the number of Barr bodies that would be seen in the following genotypes

46 XO 46 XY 46 XXY 46 XXXY

- a) 0,1,1,2 b) 0,0,1,2
c) 0,1,2,3 d) 0,0,1,1

Q50. Which of the following is an example of active acquired immunity?

- a) Nursing mother transfers some antibodies to infant through colostrum (Breast milk).
b) Person recovered from measles does not get measles again.
c) Injection of antitetanus is given after injury.
d) We do not suffer from Distemper, a fatal canine disease.

Q51. The heat of formation of carbon dioxide is X_1 and that of water is X_2 . Any hydrocarbon on combustion gives carbon dioxide and water. Ethyne is a hydrocarbon whose formula is C_2H_2 . Heat of combustion of ethyne is X_3 . With the above data predict what will be the heat of formation of ethyne.

- a) $X_1 + X_2 - X_3$
b) $2X_1 + X_2 - X_3$
c) $-2X_1 - X_2 + X_3$
d) $-2X_1 - 2X_2 + X_3$

Q52. An overhead crane is being erected to construct a multi storied building. The horizontal arm of the crane has a linear mass density of 100 kg/m and is 50 m in length. Its short arm on the opposite side of the support is 5 m long. A pulley block on the long arm, which can be moved along the arm, weighs 500 kg. Ignore the mass of the vertical frame. The vertical frame will twist and break if there is an excess imbalance of more than 10 percent. What is the minimum counter balance required on the short arm which is to be installed on a permanent basis.

- a) 27000 kg b) 29750 kg
c) 26750 kg d) 25000 kg

Q53. One set of plants was grown at 12 h day and 12 h night period cycles and it flowered. While for another set of the same plant, the night period was interrupted by a flash of light at mid night and it did not flower. The plants used for the above set of experiments are

- a) Long day plant
- b) Day neutral plant
- c) Short day plant
- d) Darkness neutral plant

Q54. Mayuri was performing thermometric titration and she took 100 ml of 1 M sulphuric acid and started adding 1M calcium hydroxide and she plotted a graph of temperature vs volume of the titrant added. In that experiment she found that temperature was initially increasing and then it started decreasing. The maximum of the graph is obtained at 100 ml. Calcium hydroxide. What will be the enthalpy change of this reaction.[Given $\Delta H = -13.7$ kcal for equivalent.]

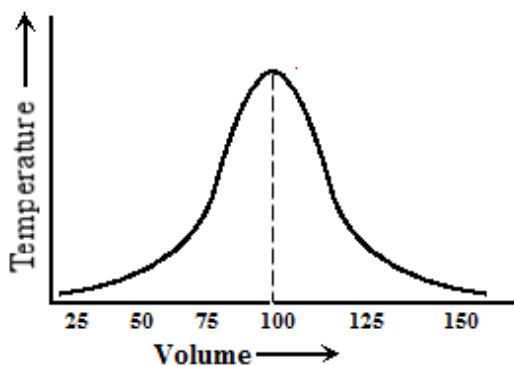

- a) -13.7 kcal
- b) -27.4 kcal
- c) -1.37 kcal
- d) -2.74 kcal

Q55. BSA was injected into rabbit as antigen and polyclonal antibody was obtained. From this polyclonal antiserum IgG fraction was purified by standard methods. If the same lot of IgG polyclonal antibodies are digested either with Pepsin or papain and subsequently incubated with the antigen (BSA); find out correct option from the following.

- a) Pepsin digested IgG will precipitate the antigen.
- b) Papain digested antibody will precipitate the antigen.
- c) Both the antibody will precipitate antigen.
- d) None of them will precipitate.

Q56. Assertion (A): If the volume of the vessel is doubled then for the following reaction.

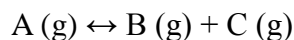

Equilibrium constant is decreased.

Reason (R): Equilibrium constant $K_c = X^2 / (1 - X) V$

- a) Both (A) and (R) are true and (R) is the correct explanation of (A).
- b) Both (A) and (R) are true and (R) is not the correct explanation of (A).
- c) (A) is true but (R) is false.
- d) (A) is false but (R) is true.

Q57. Assertion (A): Sodium carbonate can be titrated against sulphuric acid by using either phenolphthalein or methyl orange as indicator.

Reason (R): The volume of sulphuric acid required to produce colour change for two indicators is different. :

- a) Both (A) and (R) are true and (R) is the correct explanation of (A).
- b) Both (A) and (R) are true and (R) is not the correct explanation of (A).
- c) (A) is true but (R) is false.
- d) (A) is false but (R) is true.

Q58. \vec{C} is the resultant of \vec{A} and \vec{B} . Their respective magnitudes are C, A and B. Select correct statement.

- a) C may be equal to A.
- b) $C > A$ and $C > B$.
- c) $C = A + B$.
- d) C cannot be smaller than of A and B.

Q59. T.H. Morgan discovered that all the genes in *Drosophila* are linked to four pairs of linkage groups which correspond to 4 pairs of chromosomes. Sometimes, the linkage of some genes, present at some specific distance, is broken and they show independent assortment. The most plausible reason for break in the concept of linkage would be

- a) Transposition
- b) Recombination
- c) Translocation
- d) Sister-chromatid exchange

Q60. A smooth flat horizontal turntable 4.0 m in diameter is rotating at 0.050 revs per second. A student at the centre of the turntable, and rotating with it, places a smooth flat puck on the turntable 0.50 m from the edge. Which of the following figures describes the motion of the puck as seen by a stationary observer who is standing at the side of the turntable and above the turntable?

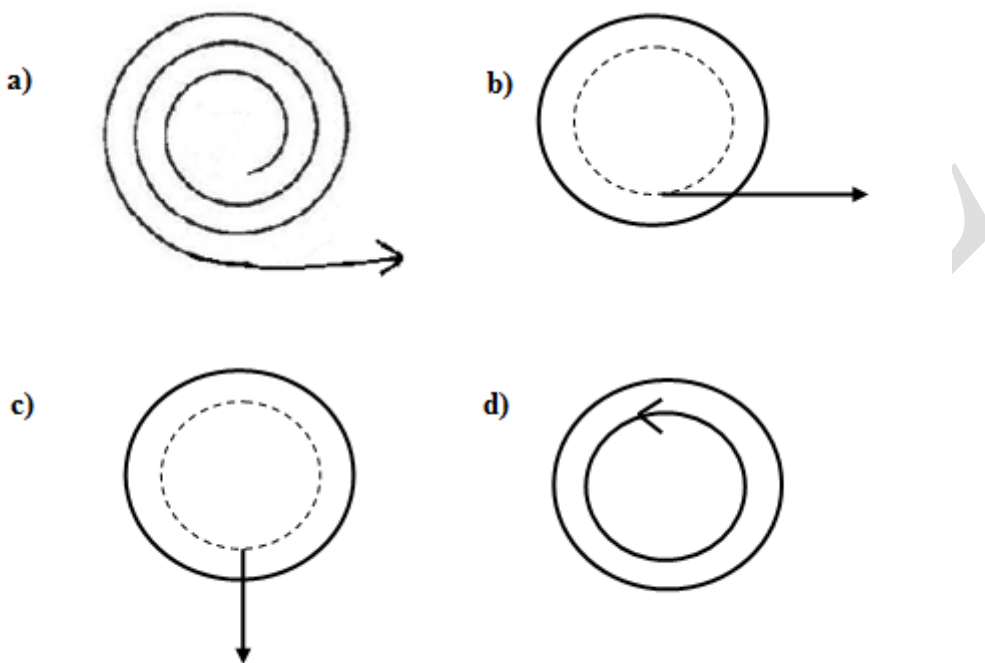

Section B: Questions 61 to 68 are of 5 marks each. Marks will also be indicated in the questions if there are more than one part to it.

SECTION B (Long questions)

Q61. Four stars A, B, C, D are in space so that the distances (in light years) between them are given by $AB = 6$, $BC = 8$, $AC = 10$, $AD = 8$ and $CD = 6$. Find the maximum and minimum possible distances between B and D. **[5 Marks]**

Q62. In the A, B and O blood grouping system, the blood group 'O' is recessive to 'A' and 'B' and 'A' and 'B' are co-dominant. Three alleles, namely, I^A , I^B and I^O represent the "A, B and O" system of blood grouping.

Answer the following questions given below.

- i. X (Female) is married to Y (Male). They have three children: P (male child), Q (male child) and R (female child). The blood group of X and Y is 'A' and 'B' respectively. If the blood groups of P and R is 'B' and Q is 'AB', predict the possible genotypes for blood groups of all the five members of the family. **[2 Marks]**
- ii. What will be the possible phenotypes and genotypes of the off-springs if the father has 'O' blood group and the mother has 'A' blood group? **[0.5 Marks]**
- iii. Given below are different blood groups and their genotypes. Find out and write the antigens present on the RBC surface for each blood group (viz: A antigen or B antigen or nil antigen) and the antibody produced in the serum of each blood group (viz: anti-A or anti-B or nil antibody) in the table provided below. **[2 Marks]**

BLOOD GROUP PHENOTYPE	GENOTYPE	ANTIGEN ON THE SURFACE OF RBC	SERUM ANTIBODY
O	$I^O I^O$		
A	$I^A I^A$ or $I^A I^O$		
B	$I^B I^B$ or $I^B I^O$		
AB	$I^A I^B$		

- iv. Which combinations of the following blood groups are the universal donors and universal recipients respectively? The letter A, B, O represent the blood group and +ve and -ve represent the Rh factor. **[0.5 Marks]**
 - a) O +ve and AB +ve
 - b) O +ve and AB -ve
 - c) O -ve and AB +ve
 - d) O -ve and AB -ve

Q 63. Observe the Nitrogen cycle given below and answer the following questions.

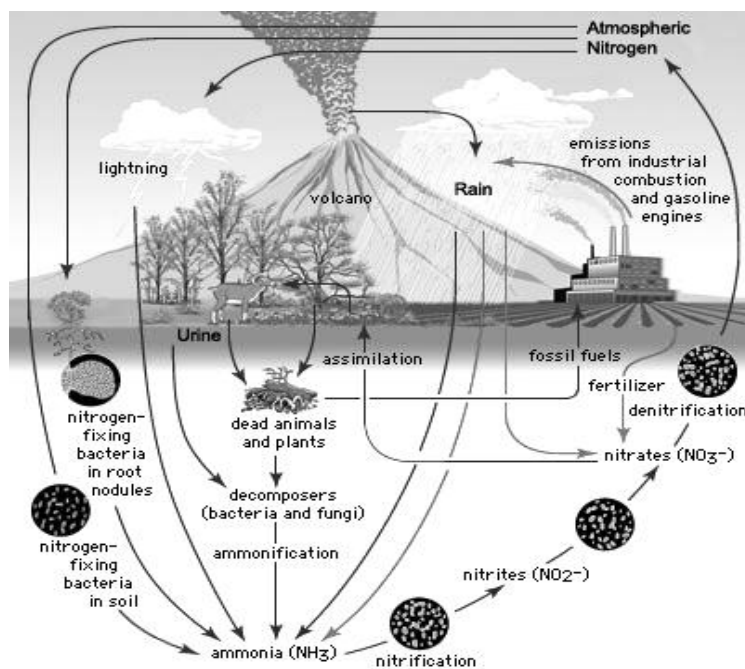

- i.** Beginning with free atmospheric nitrogen, arrange the following processes of nitrogen cycle in proper order. **[1 Mark]**
- Ammonification
 - Nitrogen fixation
 - Denitrification
 - Nitrification
- ii.** State whether the following statements are true (T) or false (F). **[3 Marks]**
- Plants get their nitrogen supply as nitrates and ammonium ions dissolved in water.
 - Ammonification refers to conversion of free nitrogen to ammonia.
 - Nitrogen is fixed only by microorganisms.
 - Rhizobium* and *Azotobacter* are both found in root nodules of leguminous plants.
 - Much of the efforts of nitrogen fixing organisms are neutralized by the action of denitrifying bacteria.
 - Volcanic eruption adds free nitrogen to the atmosphere.

- iii. If, in an experiment, all Nitrogenase enzymes in a field are inactivated by irradiation, what will be the immediate vital effect of it? **[0.5 Marks]**
- No Fixation of nitrogen in leguminous plants of the field.
 - No Fixation of atmospheric nitrogen at all.
 - No Conversion of nitrate to nitrite in leguminous plants of the field.
 - No Conversion of nitrates to ammonia in soil of the field.
- iv. Plants having mutualistic relation with nitrogen fixing bacteria would receive nitrogen in the form of _____ from the bacteria. **[0.5 Marks]**
- Ammonium ions
 - Amino acids
 - Nitrates.
 - Nitrites

Q64. (10 %) The mass percent of MnO_2 in a sample of a mineral is determined by reacting it with a measured excess of As_2O_3 in acid solution, and then titrating the remaining As_2O_3 with standard KMnO_4 . A 0.225 g sample of the mineral is ground and boiled with 75.0 mL of 0.0125 M As_2O_3 solution containing 10mL of concentrated sulfuric acid. After the reaction is complete, the solution is cooled, diluted with water, and titrated with $2.25 \times 10^{-3}\text{M}$ KMnO_4 , requiring 16.00ml to reach the endpoint.

Note: 5 mol of As_2O_3 react with 4mol of MnO_4^- .

- Write a balanced equation for the reaction of As_2O_3 with MnO_2 in acid solution. The products are Mn^{2+} and AsO_4^{3-} . **[1Mark]**
 - Calculate the number of moles of
 - As_2O_3 added initially. **[1 Mark]**
 - MnO_4^- used to titrate the excess As_2O_3 . **[1 Mark]**
 - MnO_2 in the sample. **[1 Mark]**
 - Determine the mass percent of MnO_2 in the sample. **[0.5 Mark]**
 - Describe how the endpoint is selected in the KMnO_4 titration **[0.5 Mark]**
- Q65.** A particle is moving on the real line, and its position is observed at four different time stamps. At time $t = 0$, the particle is at $x = 0$, at time $t = 20$ seconds, we have $x = 40$, at time $t = 40$ seconds, $x = 60$ and at time $t = 60$ seconds, we have $x = 90$. Show that at some point of time between 0 and 60 seconds, the acceleration of the particle was zero. **[5 Marks]**

Q66 a. In the Panchatantra stories, one of the popular stories is where a crow sits on a pot partially filled with water. Crow could not reach up to the water level and so decides to put in some stones so that the water level rises up to a point from where crow could drink the water. Let us see if this is possible.

Assume that the container is rectangular in shape with base of 10 cm x 20 cm and height of 30 cm. Crow has marbles of radius 1 cm to pack the container. Crow packs the base of the container tightly with a set of marbles. All the subsequent layers are similar.

- i. What should be the initial level of water such that any kind of packing will certainly bring the water level up to the brim of the container so that it can drink the water? **[1Marks]**
- ii. What is the minimum number of marbles required to do the job? **[1Marks]**

Q66 b. Comet ISON, which several astronomy enthusiasts had hoped would be the 'comet of the century', recently disappointed sky observers by breaking apart before reaching its peak brightness, rendering it too dim to be visible by the naked eye. In this problem we will consider a simplistic model to try and model the breakup of the comet.

The breakup of the comet was attributed to the strong effect of tidal forces acting on the comet due to the sun. These are the same tidal forces that lead to the commonly observed effect of tides on the earth. Tidal forces are nothing but a result of the difference of the gravitational attraction at the two ends of the object.

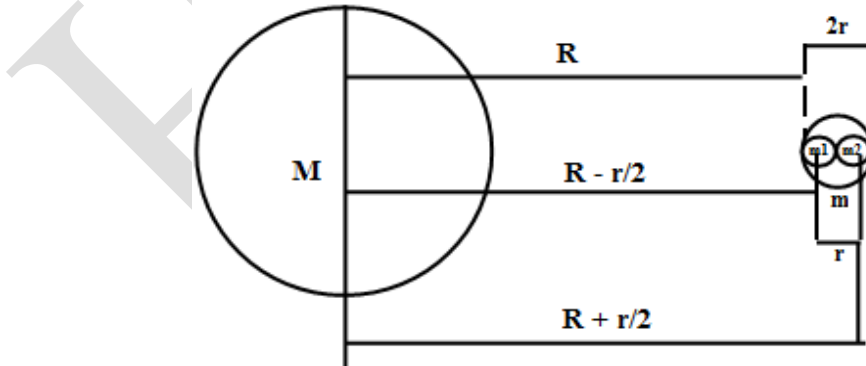

ISON is made of two identical spheres (m_1, m_2) attached to each other. As seen from the sun, one sphere is exactly behind the other sphere. Let total mass be m and distance between centers of two spheres be r . Let the distance of closest approach of the comet from the sun, when it broke, be R . (Distance of closest approach means, the distance between the comet and the sun, is smallest).

- i. What is the mutual gravitation force by two spheres on each other? [0.25Marks]
- ii. What gravitation force of sun on closer sphere? [0.25Marks]
- iii. By comparing the difference in forces on each of the 2 halves, with respect to the mutual force between the two halves, give a relation by governing when the comet would break up. [1.5Marks]
- iv. Convert this relation to find an upper limit on the density of the comet. [1Marks]
- Q67.** The purpose of an air bag is to slow the passenger's forward movement into the steering wheel (or dash board) during a collision and also to provide a cushion between the passenger and the steering wheel. The goal of an air bag is to help the passenger come to a stop with minimum damage. One of the ways an air bag helps reduce injury is by spreading the force of impact with the dashboard or steering wheel over a larger area, as illustrated in Figure 1. When the force is spread over a larger area of the body, the injuries are less severe.

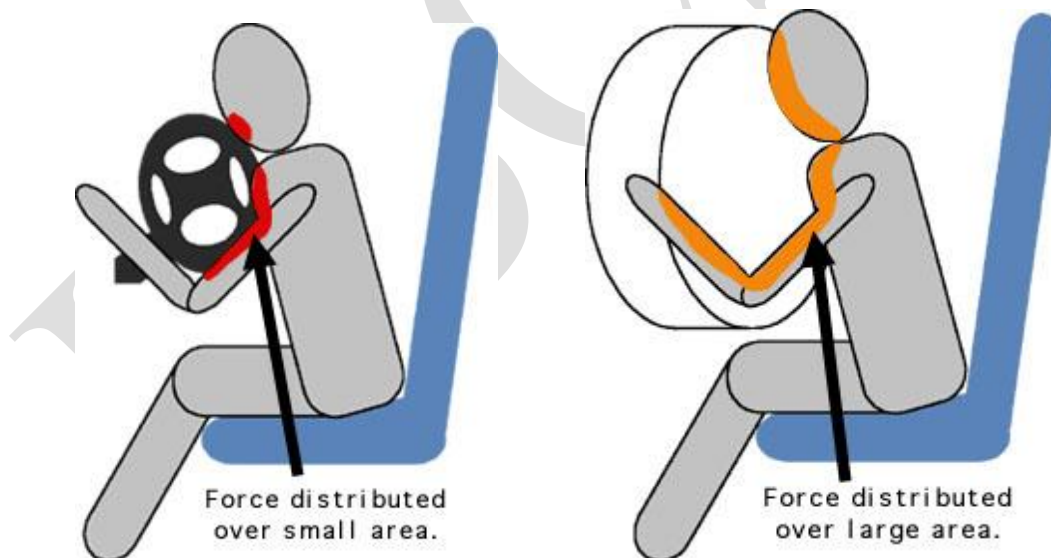
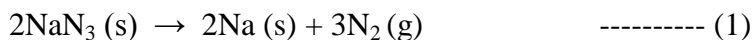

Figure 1. Force distribution during collision comparing air bag to no air bag.

A certain model of car is equipped with 65.0 liter air bag that inflates to 89.4 m/s in 40 milliseconds. The weight of air bag is 2.0 Kg and the thickness of fully inflated air bag is 30.0 cm.

One method used to inflate air bags in cars is to use nitrogen produced chemically from the decomposition of sodium azide:



The sodium formed reacts with potassium nitrate to give more nitrogen:

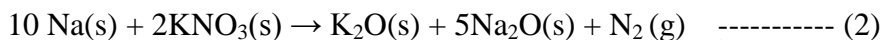

- i. Calculate the ratio (by mass) in which the sodium azide and potassium nitrate should be mixed in order that no metallic sodium remains after the reaction.

[1 Mark]

Na_2O and K_2O , are highly reactive, so it would be unsafe to allow them to be the end product of the airbag detonation. These metal oxides react with silicon dioxide (SiO_2) in a final reaction to produce silicate glass, which is harmless and stable.

- ii. Write the reaction of SiO_2 with sodium oxide and potassium oxide. [0.5 Mark]
- iii. Calculate the total mass of the solid mixture of sodium azide and potassium nitrate needed to inflate a 72 dm^3 air bag is filled with nitrogen gas at of 1 atm and at room temperature (27°C).
Consider the molar volume of nitrogen gas as 24.0 dm^3 at 300 K and universal gas constant, $R = 0.0821\text{ liter. atm.mole}^{-1}\text{K}^{-1}$
(Important: Show all your calculation step clearly) [2 Mark]

The sodium azide is prepared commercially by the reaction between dinitrogen monoxide and sodium amide.



- iv. Calculate ΔH_r for reaction (1) above, the decomposition of sodium azide.

Given:

Compound	$\text{N}_2\text{O}(\text{g})$	$\text{NaNH}_2(\text{s})$	$\text{NaOH}(\text{s})$	$\text{NH}_3(\text{g})$
ΔH_f (KJ/mol)	+82.0	-123.7	-425.2	-46.1

[1.5 Mark]

- Q68.** Pradip lives in an apartment on 4th floor of a 6 story building in Mumbai. It has an overhead water tank which is just above the 6th floor. It is kept always full by an automatic pump. He loves to have bath in hot water at 35⁰C, even in summer even when the outside temperature is 30⁰ C. He uses a 3000 watt instant water heater for his shower. The hot and cold water taps in his bathroom are similar, and each can only be in the ON or the OFF state. In the summer he has to open the cold water tap allowing equal volume of cold water to be mixed with the output of the heater. As he believes in the water conservation theory of Hugo Chavez, former president of Venezuela, he completes his shower exactly in 3.5 min.
- i.** Estimate the temperature of the water flowing out of the heater. (Assume no heat is lost when the water flows through the pipe to the shower). **[0.5 marks]**
 - ii.** What is the rate of flow of water into the water heater fitted on the 4th floor of the building? **[1 mark]**
 - iii.** How much water does Pradip use for every shower? **[0.5 marks]**
 - iv.** In winter the outside temperature is 25⁰C. Keeping the water flow rate into the heater the same as in the summer, to what extent he should open the cold water tap (if it is possible to control the flow) to get the same temperature shower as in the summer? **[1 mark]**
 - v.** Vinayak lives on the second floor of the same building. Both Vinayak and Pradip have identical taps and heaters. Assuming all other physical conditions are identical, if Vinayak maintains the taps open or closed through the year following the same pattern as Pradip, then what are the temperatures of water Vinayak receives in the summer and winter? **[2 mark]**